

EWART CHAIN LTD
GLOBAL SUPPLIER

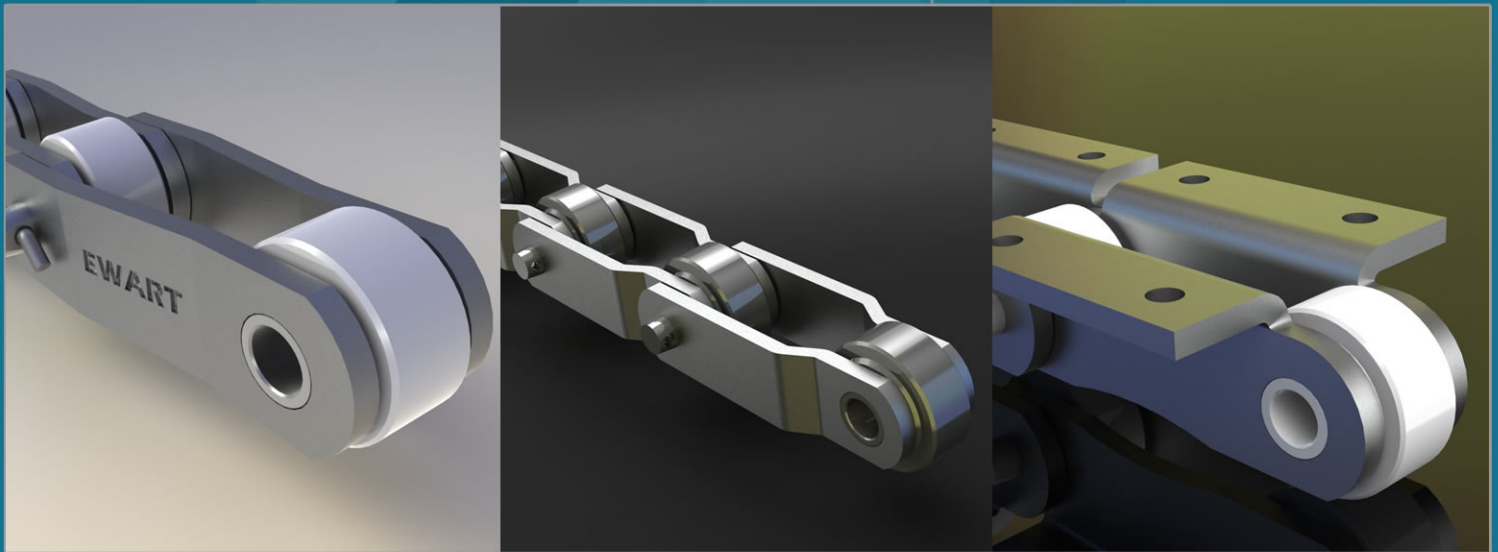

Sugar Industry Chains

EWART CHAIN Ltd est 1880



Ewart Chain Ltd

THE BEST KNOWN CHAIN BRAND IN THE WORLD





In eighty countries around the world, the name Ewart is a synonym for high quality power transmission, conveying and elevator chains. Wherever such steel, malleable or plastic chains are used – in sugar mills, quarries, sawmills, water purification or bottling plants, on conveyors, elevators, excavators or scrapers – Ewart chains are likely to be standard equipment and Ewart will certainly be the first choice for replacement links.

Ewart Chain Ltd is situated in Derby. Some 80% of production is directly exported. Indirect exports account for a further 15%. In order to handle this international business in the most efficient manner possible, Ewart Chain have kept abreast of the advances in office technology to ensure fast and accurate processing of enquiries from any part of the world.

Conveyor Elevator and Power Transmission Chains

The Steel and Malleable iron chain for which Ewart are already highly regarded, include, Steel Drive, Conveyor, Rivetless and Bushed varieties, a mixture of Steel and Malleable in the combination chains and the Ley Bush, Gray Pin, Roller and Drag Link chains in malleable iron as well as Intercarrier chains which are available in stainless steel. Ewart's hard won reputation for rugged reliability and durability, even under the most arduous operating conditions, stems from many years of practical research into component design, materials and heat treatment procedures. To this must be added the company's whole-hearted commitment to quality control, ranging from the stringent metallurgical inspection of all incoming material through to batch sampling and the destruction testing of randomly sampled finished products.

Contents

Cane field chains	2
Drive chains	3-4
Cane feeder & washing table chains	5-13
Main & auxiliary cane carrier chains	14-20
Intermediate carrier roller chains	21-30
Bagasse elevator & conveyor chains	31-33
Juice strainer (cush-cush) chains	34
Trash conveyor chains	35
Slats, sprockets & buckets	36-37
Sugar elevator chains	38-48
Boiler Chains	49-50
General installation & maintenance instructions	51-55



Cane Field Chains

Ewart offers a variety of chains for use in the harvesting of cane. Numerous types of roller and double pitch roller chains are available. The Hollow Pin Type Chain is shown.

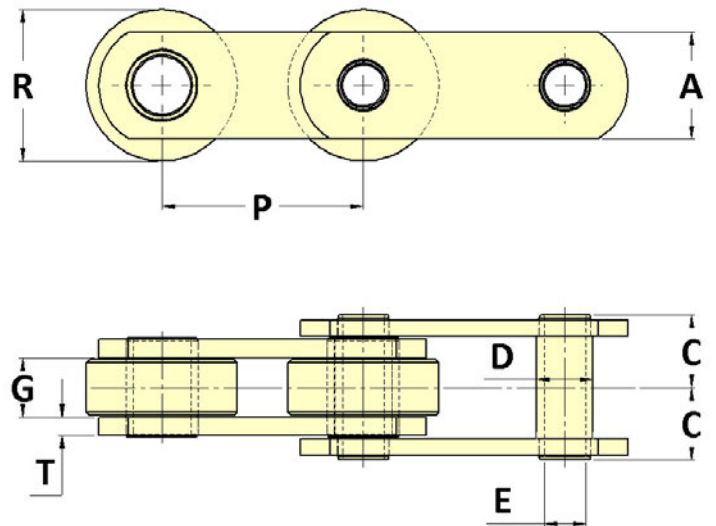
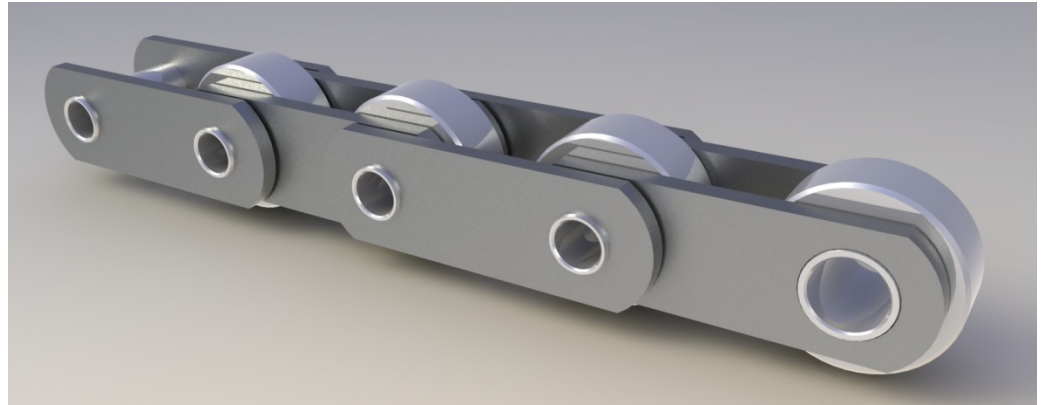

CHAIN No	PITCH P	ALLOW LOAD	UTS LBS	LINKS IN 10FT	WEIGHT LB/FT	SIDEBAR DEPTH A	C	D	E	MAX GEARING G	ROLLER DIA R	T
SS2038	2,500	3,400	21,000	48	10.1	1.750	.94	.992	.765	.813	1.56	.19
EHP200	2,000	2,600	12,000	60	3.2	1.06	0.72	0.56	0.41	0.59	1.5	0.16

* The tabular dimensions and weights are approximate and are not binding. Design improvements may result in variation from the published figures and verification is recommended.



Drive Chains

Ewart Sugar Drive Chains are of an all steel construction, built for operation under exposed conditions, where dirt, oil and corrosion are present.

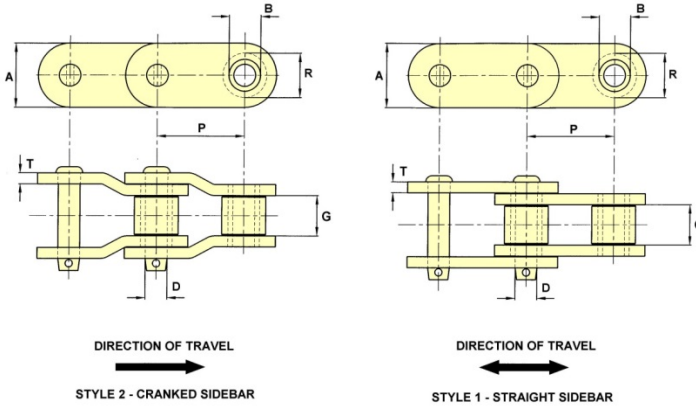
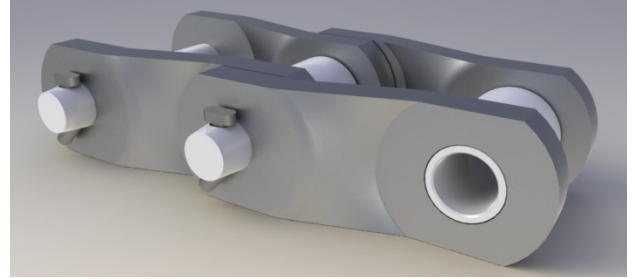

CHAIN NO.	PITCH P	ALLOW. LOAD	U.T.S.	PIN DIA. D	ROLLER DIA. R	SIDEBAR DEPTH A	SIDEBAR THICKNESS T	MAX. GEARING G	BUSH DIA. B	CHAIN WEIGHT lb/ft	CHAIN STYLE
EXS2065	2.000	3,890	65,000	0.59	1.13	1.63	0.31	1.25	0.87	7.6	2
2500X	2.500	5,190	68,000	0.62	1.25	1.63	0.31	1.50	0.91	8.8	2
64S	2.500	7,500	115,000	0.88	1.56	2.38	0.38	1.53	1.21	12.8	1
EXS882	2.609	2,500	28,000	0.44	0.87	1.13	0.25	1.13	0.64	3.6	2
EXS402	3.075	4,650	48,000	0.62	1.25	1.50	0.31	1.50	0.88	7.4	2
API3P	3.075	5,100	75,000	0.65	1.25	1.56	0.38	1.50	0.91	8.6	2
1190EXX	3.075	5,100	100,000	0.65	1.25	1.75	0.38	1.50	0.91	8.3	2
3012	3.067	6,000	110,000	0.75	1.63	2.25	0.38	1.56	1.13	13.9	2
3067X	3.067	6,000	110,000	0.75	1.63	2.00	0.38	1.58	1.13	12.0	2
2512 #	3.067	6,410	115,000	0.75	-	2.13	0.38	1.50	1.25	11.0	2
B7811	3.075	5,100	100,000	0.65	1.25	1.75	0.38	1.50	0.91	8.3	2
E3114	3.090	7,650	140,000	0.88	1.75	2.25	0.50	1.50	1.25	17.5	2
E238R	3.500	7,650	150,000	0.88	1.75	2.25	0.50	1.50	1.25	16.0	2
3514	3.500	7,650	150,000	0.88	1.75	2.25	0.50	1.50	1.25	16.7	2
1664A	4.000	14,700	250,000	1.19	2.25	3.25	0.56	2.19	1.63	28.6	2
API4P	4.063	9,000	150,000	0.88	1.75	2.25	0.50	2.00	1.25	15.7	2
4014	4.063	9,000	150,000	0.88	1.75	2.25	0.50	2.00	1.25	15.7	2
RX1245	4.073	10,050	170,000	0.94	1.78	2.38	0.56	1.94	1.31	18.7	2
4015A	4.073	10,050	170,000	0.94	1.78	2.38	0.56	1.94	1.31	18.7	2
E4073	4.073	11,500	170,000	1.00	1.78	2.38	0.56	1.94	1.31	18.7	2
4016	4.090	11,500	170,000	1.00	1.87	2.75	0.56	1.94	1.31	22.6	2
4016LR	4.090	11,500	170,000	1.00	2.00	2.75	0.56	1.94	1.31	23.3	2
4500A	4.500	12,200	208,000	1.09	2.25	3.00	0.56	2.06	1.63	24.5	2
EXS5026	5.000	16,130	260,000	1.25	2.50	3.25	0.56	2.56	1.88	31.1	2
5020	5.000	17,500	260,000	1.25	2.50	3.50	0.56	2.75	1.88	35.1	2
EXS5027	5.000	17,500	260,000	1.25	2.50	3.25	0.63	2.75	1.88	35.1	2
1605AAA	5.000	21,000	330,000	1.38	2.50	3.50	0.75	2.56	1.88	39.8	2
5022	5.000	21,000	330,000	1.38	2.50	3.50	0.75	2.56	1.88	39.8	2
E1605	5.000	22,200	330,000	1.38	2.50	3.50	0.75	2.75	1.88	40.3	2
EXS5042	5.000	23,700	420,000	1.50	3.00	4.00	0.75	3.00	2.25	51.6	1
5500A	5.500	23,625	400,000	1.50	3.00	4.00	0.75	3.00	2.25	49.8	2
5524	5.500	23,700	420,000	1.50	3.00	4.00	0.75	3.00	2.25	49.8	2
6024	6.000	23,700	420,000	1.50	3.00	4.00	0.75	3.00	2.25	46.4	2
EXS6042	6.000	23,700	420,000	1.50	3.00	4.00	0.75	3.00	2.25	46.4	2

= CHAIN NO. 2512 IS A NON-ROLLER CHAIN, AND THEREFORE, THE DIRECTION OF TRAVEL IS OPPOSITE TO ROLLER CHAINS

* The tabular dimensions and weights are approximate and are not binding. Design improvements may result in variation from the published figures and verification is recommended.



Drive Chains

Pressure Feeder Chains

THESE CHAINS HAVE SPECIALLY TREATED COMPONENTS TO SUIT THIS APPLICATION

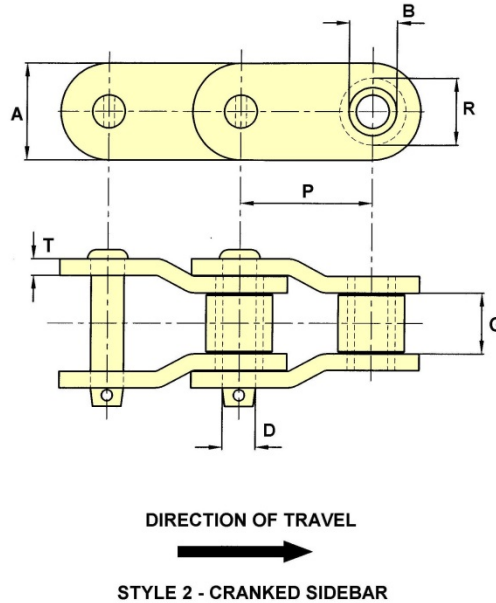

CHAIN NO.	PITCH P	ALLOW. LOAD	U.T.S.	PIN DIA. D	ROLLER DIA. R	SIDEBAR DEPTH A	SIDEBAR THICKNESS T	MAX. GEARING G	BUSH DIA. B	CHAIN WEIGHT lb/ft	CHAIN STYLE
API4P	4.063	9,000	150,000	0.88	1.75	2.25	0.50	2.00	1.25	15.7	2
4500A	4.500	12,200	208,000	1.09	2.25	3.00	0.56	2.06	1.63	24.5	2
1605AAA	5.000	21,000	330,000	1.38	2.50	3.50	0.75	2.56	1.88	39.8	2
E1605	5.000	22,200	330,000	1.38	2.50	3.50	0.75	2.75	1.88	40.3	2
XS6042	6.000	23,700	420,000	1.50	3.00	4.00	0.75	3.00	2.25	46.4	2
6042X	6.000	23,700	420,000	1.50	3.00	4.00	0.81	3.00	2.25	49.1	2
6060	6.000	40,000	600,000	1.88	3.50	4.50	0.88	4.00	2.63	66.0	2

* The tabular dimensions and weights are approximate and are not binding. Design improvements may result in variation from the published figures and verification is recommended.



Cane Feeder & Washing Table Chains

Drop Forged Chains

Drop Forged Chains are used for feeder tables and in cane washing stations. These chains are of simple construction and require no tools for assembly or disassembly.

The chain can be turned over to provide new sliding surfaces after the original side has worn.

Forged double "T" head pins provide positive locking action in the sidebars. Additionally, when worn, the pin can be rotated 180° putting the unworn pin surfaces in contact with the sidebar and centre link. This partially restores the original pitch, thereby increasing the effective life of the chain.

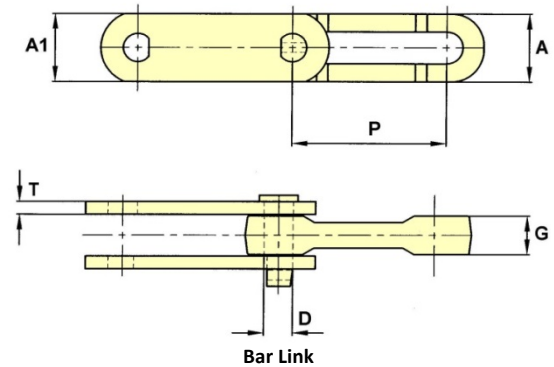
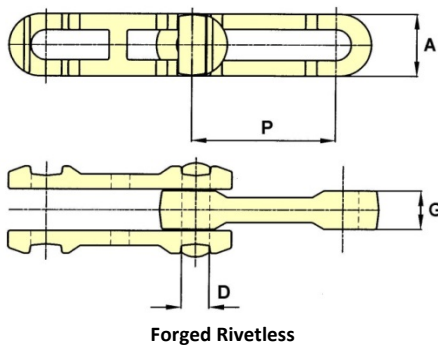
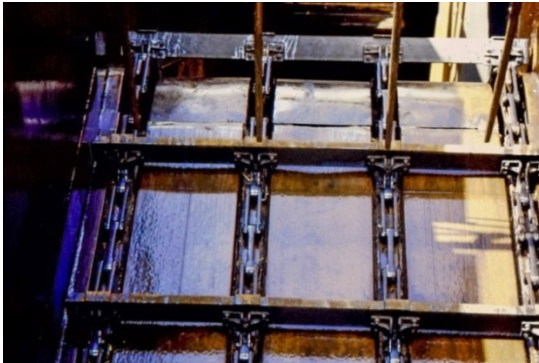
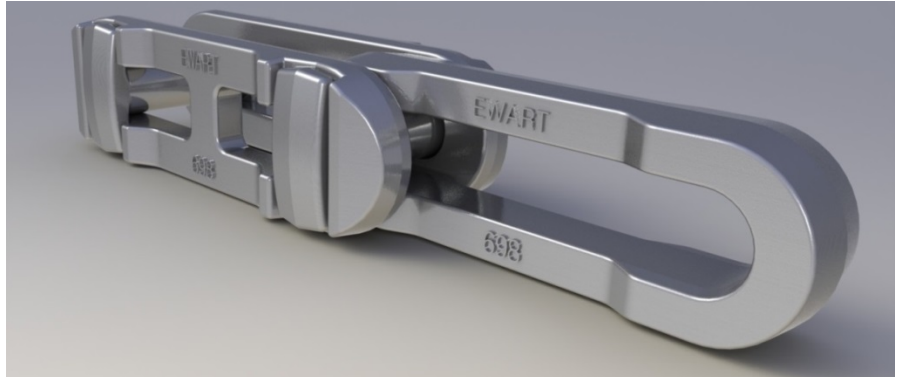

Forged Rivetless	Chain Number	Pitch P	Allow Load (Lbs)	Breaking Load (Lbs)	Weight Lb/Ft	D	MAX Gearing G	A
	348	3.015	2,400	24,000	2.2	0.5	.75	1.06
	458	4.031	3,000	48,000	3.2	0.625	1.01	1.375
	468	4.031	7,000	68,000	7.5	0.75	1.81	1.88
	678	6.031	8,500	85,000	6.7	0.875	1.29	2.00
	698	6.031	13,000	136,000	11.4	1.10	1.55	2.53
	698HD	6.031	13,000	136,000	12.2	1.10	1.55	2.69
	998	9.031	13,000	136,000	9.0	1.10	1.53	2.66
	9118	9.031	25,000	220,000	16.0	1.38	2.00	3.12

Bar Link	CHAIN NO.	PITCH P	ALLOW. LOAD	U.T.S.	PIN DIA. D	INNER SIDE DEPTH A	OUT. SIDE DEPTH A1	MAX. GEARING G	T
	S3699	6.031	6,000	130,000	1.12	2.50	2.88	1.56	0.50
	B5283	6.031	6,400	136,000	1.12	2.50	2.69	1.63	0.50

* The tabular dimensions and weights are approximate and are not binding. Design improvements may result in variation from the published figures and verification is recommended.



Cane Feeder & Washing Table Chains

Welded Steel Chains

Welded Steel Chains provide dependable operation with long wear life; the ability to accept shock loads and freedom from high maintenance costs. They provide great flexibility to Sugar Mill users since attachments can be welded easily on site.

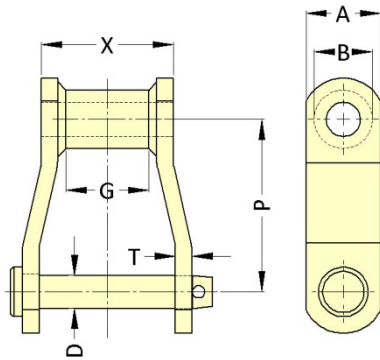
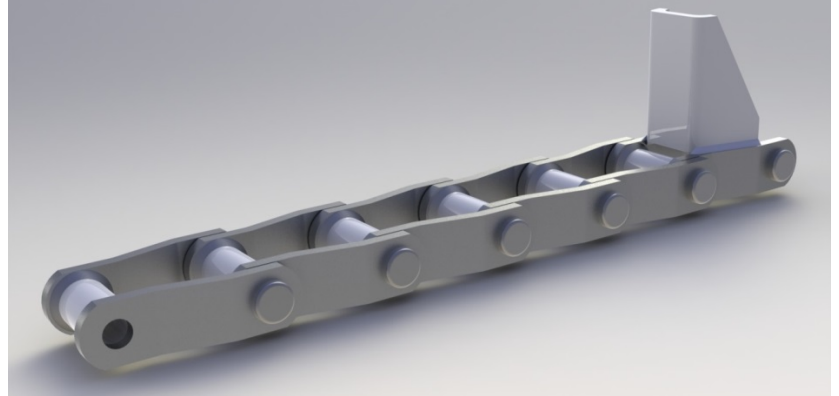

Chain No	Avg. Pitch Inches P	Rated Wkg. Load Lbs	Links Per 10 Feet	Avg. Wt. Per Foot Lbs	Length of Bearing	Rivet Diameter	Side Bar Thickness	Side Bar Width	Barrel Diameter	Max Gearing
					X	D	T	A	B	G
WH78	2.609	3,500	46	4.0	2	0.50	0.25	1.13	0.875	1.13
WH82	3.075	4,400	39	4.8	2.25	0.563	0.25	1.25	1.063	1.25
WH124	4.000	7,350	30	8.3	2.75	0.75	0.38	1.50	1.75	1.50
WH111	4.760	8,850	25	9.5	3.88	0.75	0.38	1.75	1.25	2.00
WH132	6.050	15,300	20	14.2	4.38	1.00	0.50	2.00	1.63	2.75

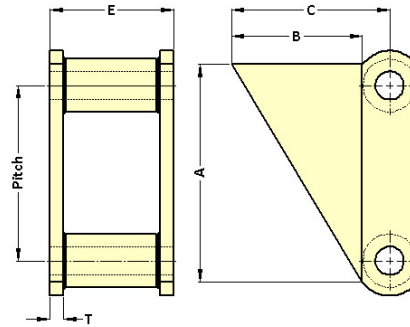
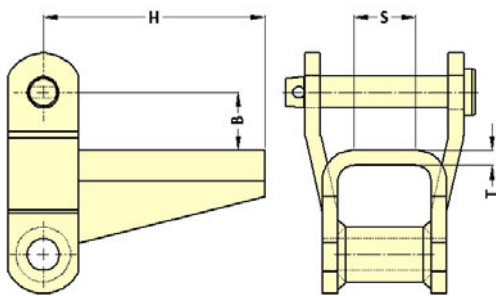

Chain	S	H	B	T	App. Wt. Per Att.
WH78	1.50	3.63	0.50	0.19	1.0 lbs
WH82	1.75	3.63	0.50	0.19	1.1 lbs

H1 Attachment

Chain	A	B	C	E	T	App. Wt Per Att
WH124	5.13	3.0	3.75	2.75	0.38	1.6 lbs
WH132	7.50	4.50	5.50	4.38	0.50	2.7 lbs

S1 Attachment

Various alternate types of attachment are available on request

* The tabular dimensions and weights are approximate and are not binding. Design improvements may result in variation from the published figures and verification is recommended.



Cane Feeder & Washing Table Chains

Welded Steel Chains

S1 Attachment

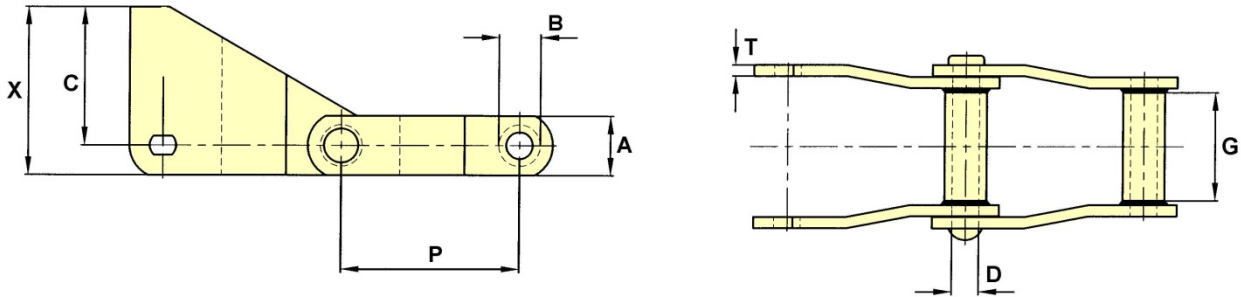

Can be supplied as a separate welded on piece to standard sidebar

CHAIN NO.	PITCH P	ALLOW. LOAD	U.T.S.	PIN DIA. D	SIDEBAR DEPTH A	MAX. GEARING G	BUSH DIA. B	C	X
WH124	4.000	6,200	47,000	0.75	1.50	1.50	1.25	3.25	4.00
WH132	6.050	13,000	100,000	1.00	2.00	2.88	1.75	5.00	6.00

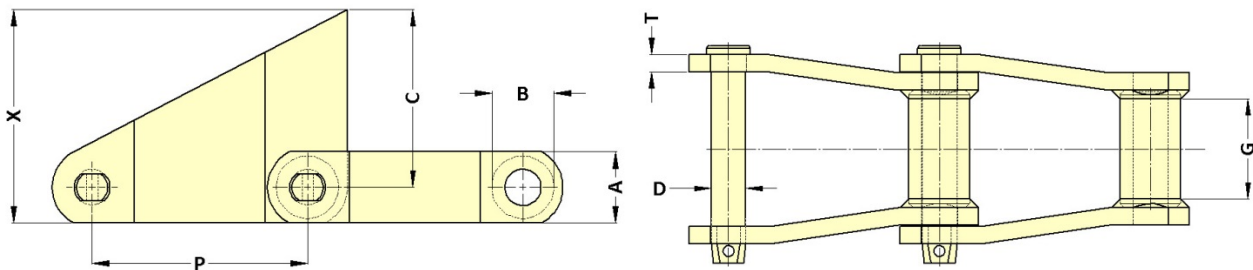

CHAIN NO.	PITCH P	ALLOW. LOAD	U.T.S.	PIN DIA. D	SIDEBAR DEPTH A	MAX. GEARING G	BUSH DIA. B	C	X
WH132	6.050	13,000	100,000	1.00	2.00	2.88	1.75	5.00	6.00

A number of additional attachments are available on request including the A22 / A42 lug type attachment.

* The tabular dimensions and weights are approximate and are not binding. Design improvements may result in variation from the published figures and verification is recommended.



Cane Feeder & Washing Table Chains

Combination Chains

Combination Type Chains have cast block links alternating with steel sidebars. This configuration provides an ideal compromise between strength, stability and price.

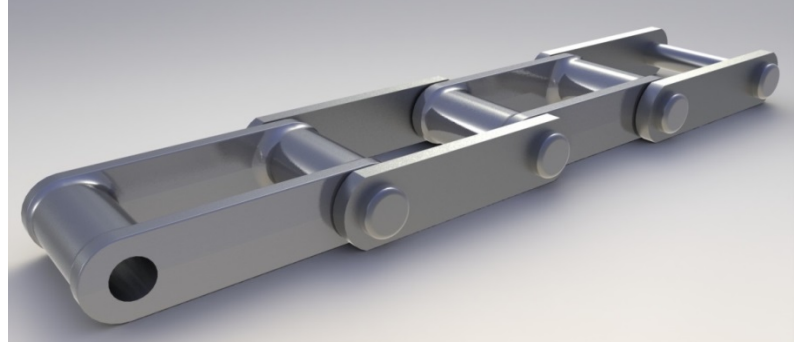

S1 Attachments

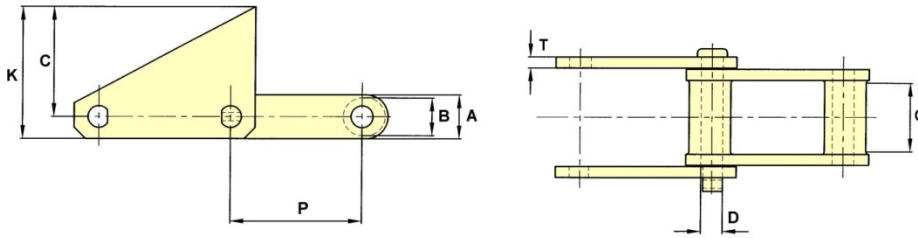

Chain No	Pitch Inch	Allowable Chain Pull (Lbs)	Breaking Load		Plain Weight Lb/Ft	A	B	C	D	G	K	T
			LB	KGf								
C131	3.07	3,220	27,500	12,400		1.50	1.25	3.25	0.62	1.13	4.00	0.38
C 102B	4.00	4,200	27,500	12,485	7.5	1.50	1.00	3.75	0.625	1.75	4.50	0.38
C 110	6.00	4,200	27,500	12,485	6.5	1.50	1.25	4.25	0.625	1.75	5.00	0.375
C 111	4.76	6,000	36,000	16,344	9.8	1.75	1.438	4.38	0.75	2.25	5.25	0.375
C132	6.05	10,000	60,000	27,240	14.5	2.00	1.72	5.00	1.00	2.88	6.00	0.50
C132	6.05	10,000	60,000	27,240	14.5	2.00	1.72	8.00	1.00	2.88	9.00	0.50
C132	6.05	10,000	60,000	27,240	14.5	2.00	1.72	10.00	1.00	2.88	11.00	0.50

Attachment Data

S1 attachments are one piece sides flame cut to close limits to ensure maximum strength and accuracy. Standard practice is to supply these in pairs but single S1's can be supplied. K2 attachments may be used in this application and are available on request.

Eccentric Barrels

The above Ewart Combination Chains have eccentric barrels. The extra thickness occurs on the pitch line at the outer ends of the centre link. This ensures the leading barrel is clear of the sprocket tooth face. The elimination of severe sliding contact under heavy pressure reduces the extent of the wear, to which, block links of symmetrical barrel design are prone.

* The tabular dimensions and weights are approximate and are not binding. Design improvements may result in variation from the published figures and verification is recommended.



Cane Feeder & Washing Table Chains

Steel Chains Pusher Type

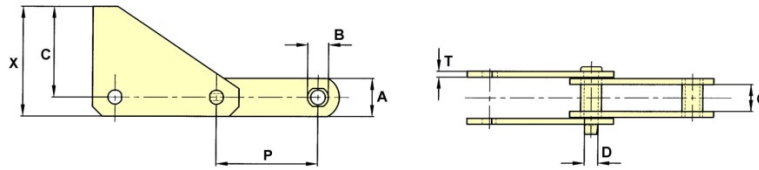

CHAIN NO.	PITCH P	ALLOW. LOAD	U.T.S.	PIN DIA. D	SIDEBAR DEPTH A	MAX. GEARING G	BUSH DIA. B	C	T	X
S82	3.075	4,300	35,000	0.62	1.50	1.37	1.19	5.19	0.25	5.94
SS102B	4.000	6,300	40,000	0.62	1.50	2.13	1.00	3.75	0.38	4.50
SS110	6.000	6,300	40,000	0.62	1.50	2.13	1.25	4.25	0.38	5.50
B5298	6.000	6,550	90,000	0.75	2.38	1.55	1.38	5.00	0.38	6.19
B5143	135MM	5,575	55,000	0.75	2.00	1.50	1.10	4.88	0.31	5.88

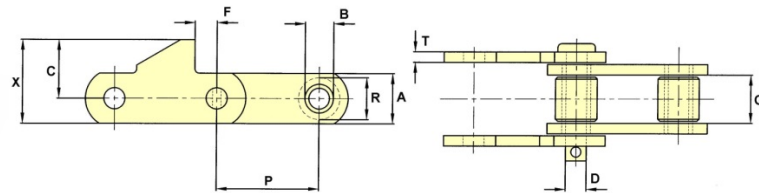

CHAIN NO.	PITCH P	ALLOW. LOAD	U.T.S.	PIN DIA. D	ROLLER DIA. R	SIDEBAR DEPTH A	MAX. GEARING G	BUSH DIA. B	C	F	T	X
SS39	3.075	4,650	48,000	0.62	1.25	1.50	1.50	0.88	1.75	0.66	0.31	2.50

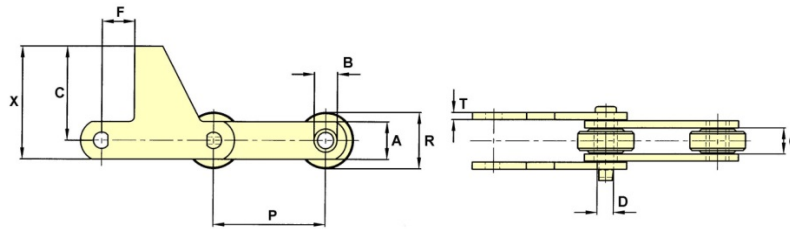

CHAIN NO.	PITCH P	ALLOW. LOAD	U.T.S.	PIN DIA. D	ROLLER DIA. R	SIDEBAR DEPTH A	MAX. GEARING G	BUSH DIA. B	C	F	T	X
B5296	6.000	7,400	90,000	0.88	2.75	2.00	1.50	1.25	5.00	1.75	0.38	6.00

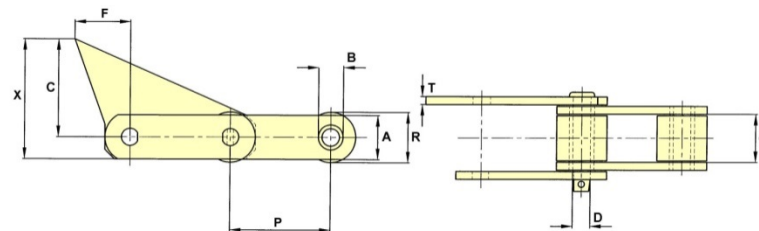

CHAIN NO.	PITCH P	ALLOW. LOAD	U.T.S.	PIN DIA. D	ROLLER DIA. R	SIDEBAR DEPTH A	MAX. GEARING G	BUSH DIA. B	C	F	T	X
B5070	4.000	6,300	40,000	0.69	2.75	2.00	2.00	1.00	3.88	2.23	0.25	4.88

* The tabular dimensions and weights are approximate and are not binding. Design improvements may result in variation from the published figures and verification is recommended.



Cane Feeder & Washing Table Chains

Steel Chains Pusher Type

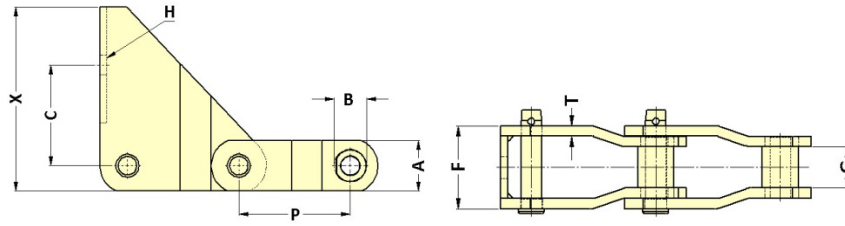

CHAIN NO.	PITCH P	ALLOW. LOAD	U.T.S.	PIN DIA. D	SIDEBAR DEPTH A	MAX. GEARING G	BUSH DIA. B	C	F	BOLT DIA. H	T	X
B5333	6.050	10,000	160,000	1.00	2.75	2.00	1.75	5.48	4.03	1.06	0.50	10.0

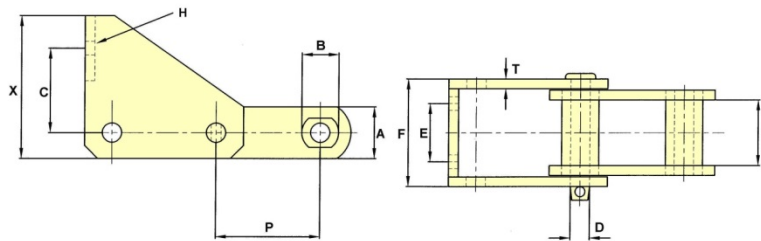

CHAIN NO.	PITCH P	ALLOW. LOAD	U.T.S.	PIN DIA. D	SIDEBAR DEPTH A	MAX. GEARING G	BUSH DIA. B	C	E	F	BOLT DIA. H	T	X
B5099	4.000	9,500	75,000	0.75	2.00	2.62	1.44	3.25	2.25	4.16	0.50	0.38	5.50

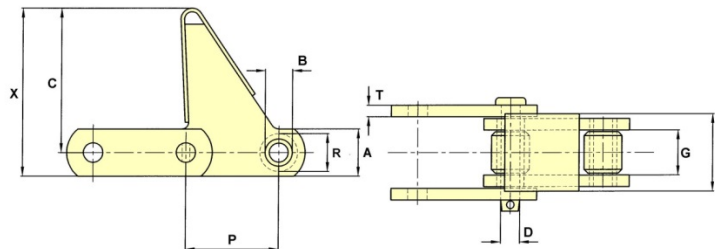

CHAIN NO.	PITCH P	ALLOW. LOAD	U.T.S.	PIN DIA. D	ROLLER DIA. R	SIDEBAR DEPTH A	MAX. GEARING G	BUSH DIA. B	C	F	T	X
B5047	3.075	5,100	70,500	0.65	1.25	1.56	1.50	0.91	4.75	2.56	0.38	5.53

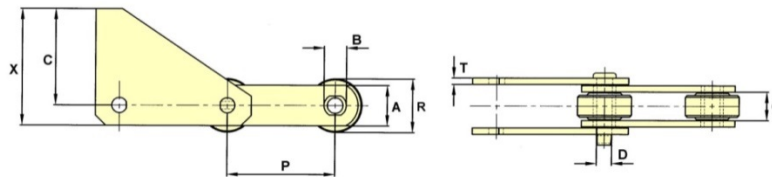

CHAIN NO.	PITCH P	ALLOW. LOAD	U.T.S.	PIN DIA. D	ROLLER DIA. R	SIDEBAR DEPTH A	MAX. GEARING G	BUSH DIA. B	C	T	X
B5191	150MM	6,200	82,500	0.88	66mm	2.19	1.25	1.25	3.5	0.31	4.59
SC132	6.000	10,000	100,000	1.00	49mm	2.00	3.37	1.34	5.51	0.50	6.51

* The tabular dimensions and weights are approximate and are not binding. Design improvements may result in variation from the published figures and verification is recommended.



Cane Feeder & Washing Table Chains

Steel Chains – AS2 Type

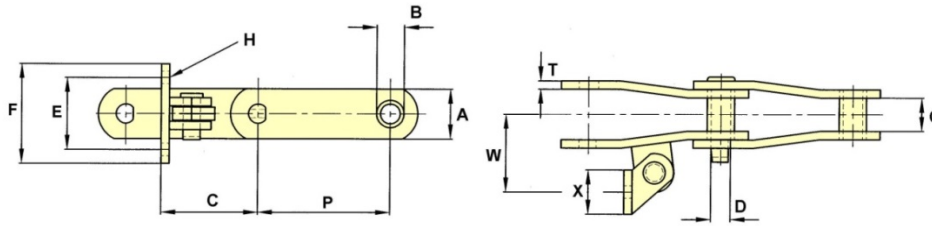

CHAIN NO.	PITCH P	ALLOW. LOAD	U.T.S.	PIN DIA. D	SIDEBAR DEPTH A	MAX. GEARING G	BUSH DIA. B	C	E	F	BOLT DIA. H	T	W	X
B5111	4.760	8,860	75,000	0.75	2.00	2.62	1.44	4.76	3.50	5.00	0.50	0.38	4.00	2

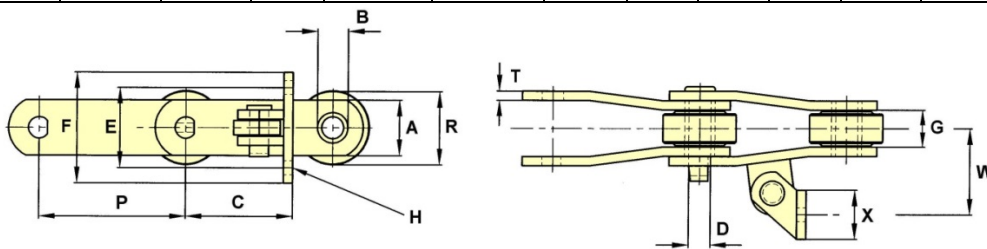

CHAIN NO.	PITCH P	ALLOW. LOAD	U.T.S.	PIN DIA. D	ROLLER DIA. R	SIDEBAR DEPTH A	MAX. GEARING G	BUSH DIA. B	C	E	F	BOLT DIA. H	T	W	X
B5276	6.050	5,900	60,000	0.75	2.63	2.00	1.38	1.00	4.40	3.25	4.50	0.50	0.38	3.38	2.00

Steel Chains – A2 Type

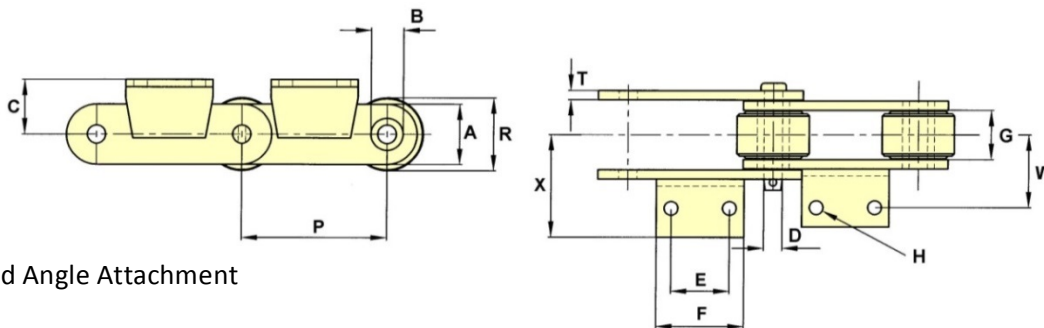

Note: Welded Angle Attachment

CHAIN NO.	PITCH P	ALLOW. LOAD	U.T.S.	PIN DIA. D	ROLLER DIA. R	SIDEBAR DEPTH A	MAX. GEARING G	BUSH DIA. B	C	E	F	BOLT DIA. H	T	W	X
6022	6.000	3,875	22,000	0.56	65MM	1.50	1.31	0.92	2.44	2.00	80MM	0.38	0.25	52MM	80MM

* The tabular dimensions and weights are approximate and are not binding. Design improvements may result in variation from the published figures and verification is recommended.



Cane Feeder & Washing Table Chains

Steel Chains – K2 Slat Type Feed Tables

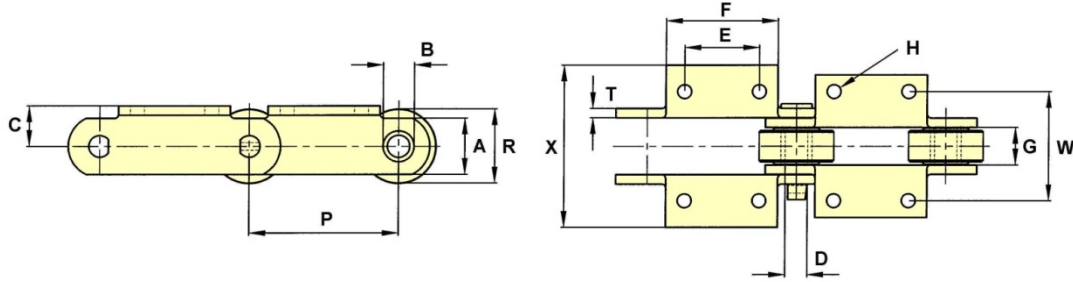

CHAIN NO.	PITCH P	ALLOW. LOAD	U.T.S.	PIN DIA. D	ROLLER DIA. R	SIDEBAR DEPTH A	MAX. GEARING G	BUSH DIA. B	C	E	F	BOLT DIA. H	T	W	X
0904	4.00	4,850	40,000	0.69	2.00	1.75	1.22	1.00	1.25	1.44	2.63	0.38	0.31	3.50	4.13
09060	6.00	6,350	60,000	0.75	2.75	2.00	1.50	1.13	1.63	3.00	4.50	0.50	0.38	4.38	6.75
09061	6.00	6,350	85,000	0.75	2.75	2.25	1.50	1.13	1.63	3.00	4.50	0.50	0.38	4.38	6.50
1796	6.00	7,500	100,000	0.87	2.75	2.25	1.50	1.25	1.63	3.00	4.50	0.50	0.38	4.38	6.50
SS2198	6.00	7,650	100,000	0.87	2.75	2.25	1.50	1.25	1.63	3.00	4.50	0.50	0.50	4.38	5.94
09063	6.00	8,300	140,000	0.94	3.00	2.38	1.50	1.25	1.75	3.00	4.50	0.50	0.41	4.38	6.50

Block Link Chains

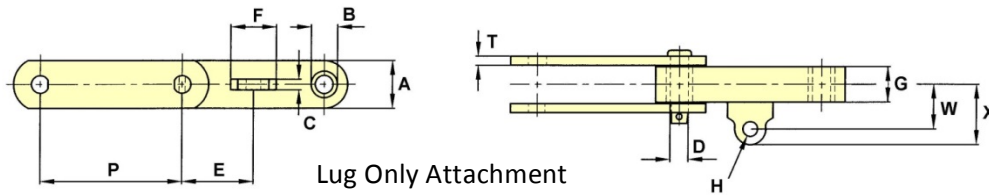

CHAIN NO.	PITCH P	ALLOW. LOAD	U.T.S.	PIN DIA. D	SIDEBAR DEPTH A	MAX. GEARING G	BUSH DIA. B	C	E	F	BOLT DIA. H	T	W	X
E30200	200MM	2,850	90,000	0.75	1.75	1.00	1.12	15MM	100MM	65MM	20MM	0.31	2.00	2.88

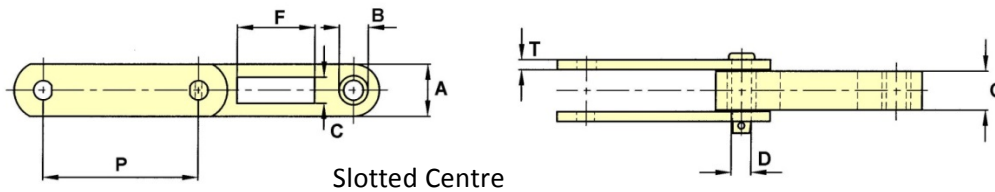

CHAIN NO.	PITCH P	ALLOW. LOAD	U.T.S.	PIN DIA. D	SIDEBAR DEPTH A	MAX. GEARING G	BUSH DIA. B	C	F	T
BL09060	6.00	4,400	60,000	0.75	2.00	40MM	1.12	28mm	75mm	0.38
BL09063	6.00	7,200	140,000	0.94	2.38	55mm	1.25	29mm	73.5mm	0.41

* The tabular dimensions and weights are approximate and are not binding. Design improvements may result in variation from the published figures and verification is recommended.



Cane Feeder & Washing Table Chains

H Class Pintle Chains

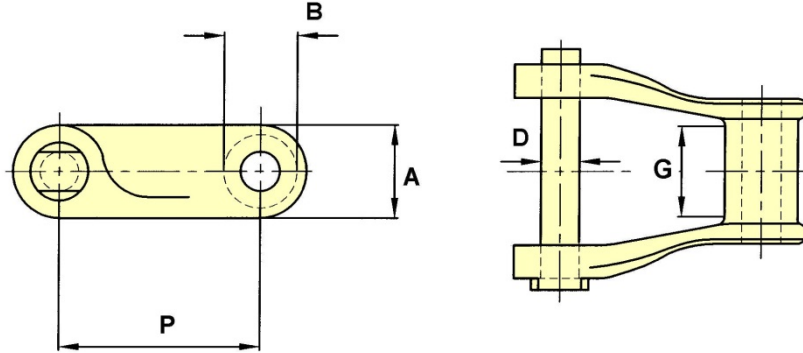

CHAIN NO.	PITCH P	ALLOW. LOAD	U.T.S.	PIN DIA. D	SIDEBAR DEPTH A	MAX. GEARING G	BUSH DIA. B
H78	2.609	2,380	16,000	0.50	1.13	1.13	0.88
H82	3.075	3,080	20,000	0.56	1.25	1.25	1.22

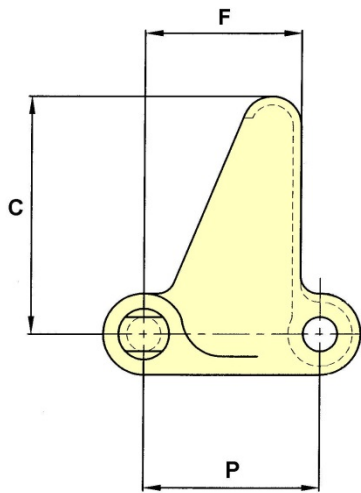

H2 Attachment

CHAIN NO.	PITCH P	C	F	X
H78	2.609	3.50	2.42	1.13

* The tabular dimensions and weights are approximate and are not binding. Design improvements may result in variation from the published figures and verification is recommended.



Main & Auxiliary Cane Carrier Chains

The Ewart 'COBRA' Apron Conveyor System

The outboard roller cane carrier chain provides numerous advantages over the conventional type roller chain.

- REDUCED FRICTION AND POWER REQUIREMENT
- INCREASED WEAR LIFE
- HIGHER FATIGUE STRENGTH
- WITHSTANDS HEAVY IMPACT
- SIMPLIFIED MAINTENANCE AND REPLACEMENT

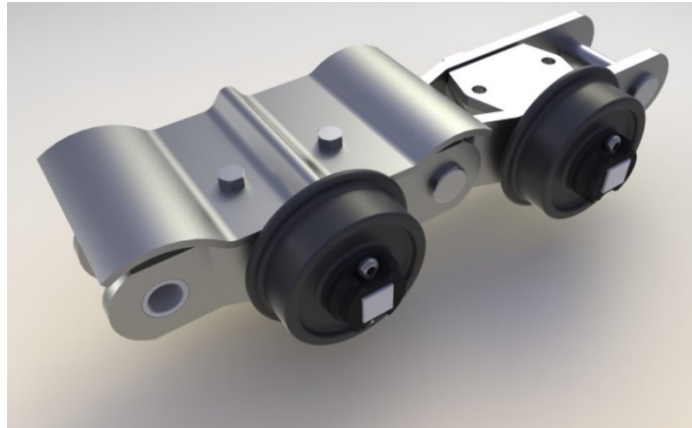

Chain

The 12 in. (304.8mm) pitch chain features large-diameter pins which in turn mean large pin/bush and bush/roller bearing areas for longer life. Pins are heat-treated and induction hardened as standard on chain number C 2630 an heat treated as standard with induction hardening and optional extra on No. C 2614. Pins are normally supplied for pressure lubrication. Notable are the close tolerances and full interference fits between chain components. As the chain is employed primarily for tension, wear takes place on contact with the sprocket. Hardened steel chain rollers minimise this wear, rolling into contact with the sprocket teeth whereas a bushed design would slide into contact.

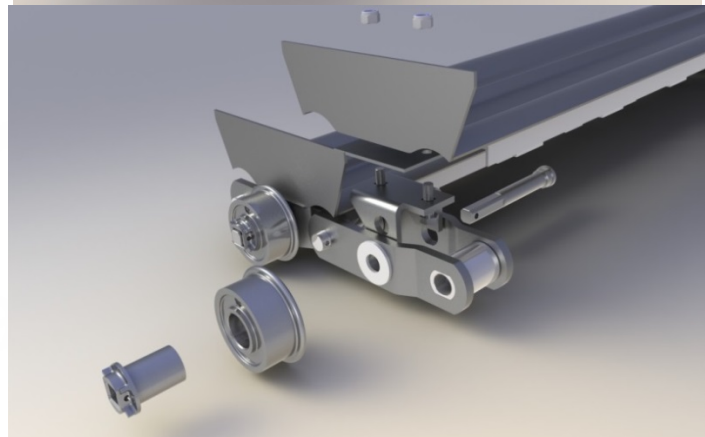

Clamping Bracket

Between the chain's sideplates is a pearlitic malleable iron clamping bracket with its clamping face set slightly below the top faces of the sideplates.

Through-Bar

Spanning the full width of the conveyor, passing through the chain sideplates and clamping bracket, is a 1 ¼ in. (32mm) square-section steel through-bar.

Carrier Rollers

A single-flanged roller, of 6in (152.4mm) tread diameter and running on a roller sleeve, is fitted to each end of the through-bar, outside the strands of chain. These non-clog track rollers are specially hardened and have large grease reservoirs. Rollers and sleeves – both of white iron for greater wear-resistance – can be removed without disturbing the chain.



Any wear on the loaded side of the sleeve can be counteracted by turning the sleeve through 90° so as to present a new wear face.



Main & Auxiliary Cane Carrier Chains

Apron

The heavy-gauge, double-corrugated overlapping slat, complete with welded-on apron sides, is clamped rigidly against the top faces of the chain sideplates, via the clamping bracket. Removal of just four clamping bolts frees the tray assembly, when required. High, overlapping apron sides guard against spillage and the generous overlap on the deeply corrugated bead sections of the slat keeps possible leakage to a minimum.

The ¼ in. or 3/8in (6mm or 10mm) thick slat is stiffened across its full span by means of angle sections welded to the underside so as to provide greater beam strength and to prevent distortion. In still more heavily loaded applications, channel instead of angle sections may be used.

Added protection against deflection is furnished by skid blocks welded at specific points along the bracing members, these points being determined by the conveyors width. The skid blocks are arranged slightly clear of the intermediate support rails fitted to the conveyor structure, those being required only at points of loading or other severe impact.

Corrosion Resistance

Stainless steel articulating components can be supplied, where corrosive conditions exist. Some form of lubrication – even steam, blown on to the main components – is then necessary, as stainless steel when used dry has inferior wear resistance to that of standard materials.

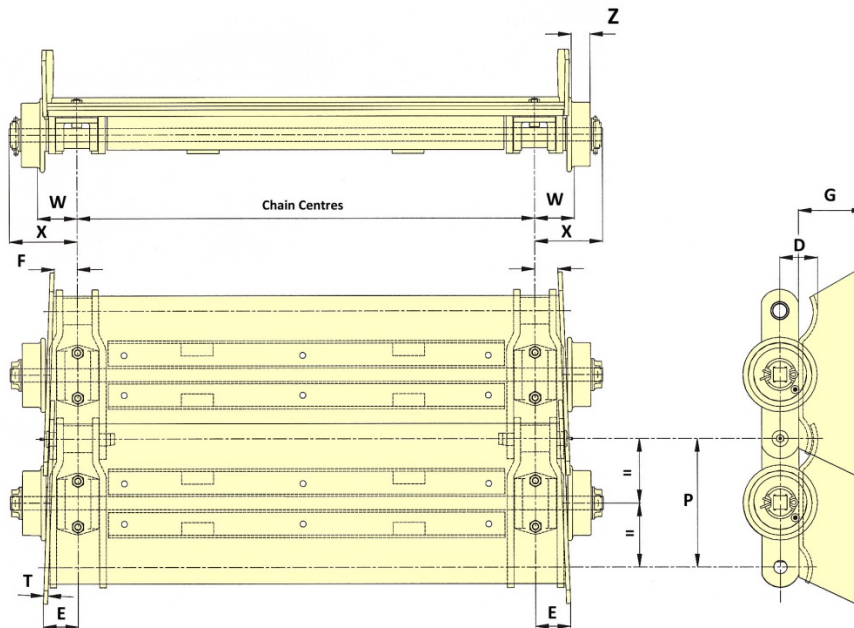

Chain No	Chain & Apron Pitch		Av. Ultimate Strength		Allowable Chain Pull		Allowable gross conveyor loading		Minimum Radius of upturn	
			Lb	kg	Lb	kg	Outboard rollers & through-bar every chain pitch	Outboard rollers & through-bar every other chain pitch		
C 2614	In. 12	mm. 304.8	140,000	63,500	19,000	8626	2,800 lb/ft 4,166 kg/m	1,400 lb/ft 2083 kg/m	Ft 12	M 3.7
C 2630			300,000	136,000	21,000	9534				
C2648			400,000	181,436	29,500	13,380				
5648			400,000	181,436	33,750	15,300				

Chain No	E	F	W	X	Roller Tread Z	Slat Thickness	C.L Chain to Top of Slat D	Sideplate Thickness T	Sideplate Height G
C2614	2.91	2.09	3.69	6.44	1.75	6mm	3.22	6mm	6.25
C2630						10mm	3.54		
C2648	3.49	2.63	4.34	8.00	2.38	8mm	3.63		
5648			4.06	7.98	2.38	8mm	3.88		

Apron slats, support angles, chain assembly, through-bars, saddles, rollers and roller bushes, bolts etc are ALL SUPPLIED SEPARATELY for final assembly on site. Slat is supplied with sideplates welded in position unless specified otherwise. Pressure lubricated chain pins are offered as standard.

* The tabular dimensions and weights are approximate and are not binding. Design improvements may result in variation from the published figures and verification is recommended.



Main & Auxiliary Cane Carrier Chains

Cranked Sided

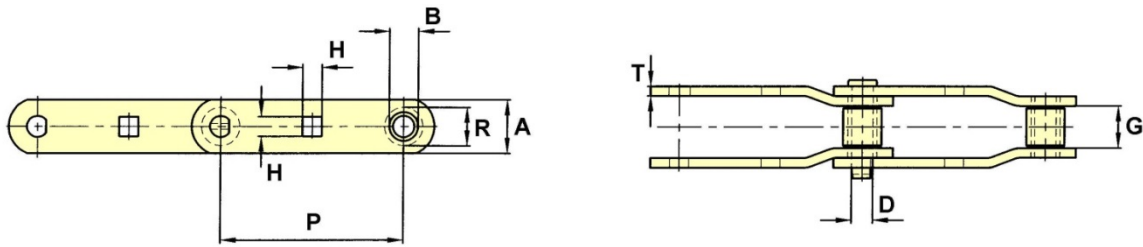

CHAIN NO.	PITCH P	ALLOW. LOAD	U.T.S.	Weight Lbs/ft	PIN DIA. D	ROLLER DIA. R	SIDEBAR DEPTH A	MAX. GEARING G	BUSH DIA. B	BAR DIA. H	T
E9112	9.000	9,000	120,000		0.87	1.75	2.50	1.94	1.25	0.87	0.50
2397R	12.000	9,180	90,000		0.87	1.75	2.50	2.25	1.25	0.91	0.38
B5618	12.000	14,000	100,000		1.00	2.25	2.50	2.97	1.75	1.03	0.50
B5616	12.000	12,200	139,000		1.00	1.75	75MM	2.50	1.75	27MM	12MM
C2614	12.000	19,000	140,000	21.93	1.25	2.50	3.50	2.75	1.75	1.25	0.63
R1706	12.000	19,000	140,000	12.97	1.00	2.25	2.50	3.00	1.49	1.03	0.50
E12140	12.000	17,500	250,000		1.25	2.50	3.50	2.75	1.78	1.25	0.63
B5801	12.000	19,000	250,000		1.25	2.50	3.50	2.75	1.75	1.25	0.63
C2630	12.000	21,000	300,000	22.9	1.37	2.50	3.50	2.75	1.88	1.25	0.63
E12220	12.000	21,000	350,000		1.50	3.13	4.00	2.75	2.19	1.25	0.63
E12230	12.000	27,500	350,000		1.50	3.50	4.00	4.00	2.19	1.25	0.63
E2648	12.000	29,600	177,000		1.63	3.25	4.00	3.69			0.75
C2648	12.000	29,600	400,000	34.25	1.61	3.25	4.00	3.69	2.38	1.48	0.75
5648	12.000	33,750	400,000	39.6	1.86	-	4.50	3.68	3.24	1.25	0.75

Straight Sided

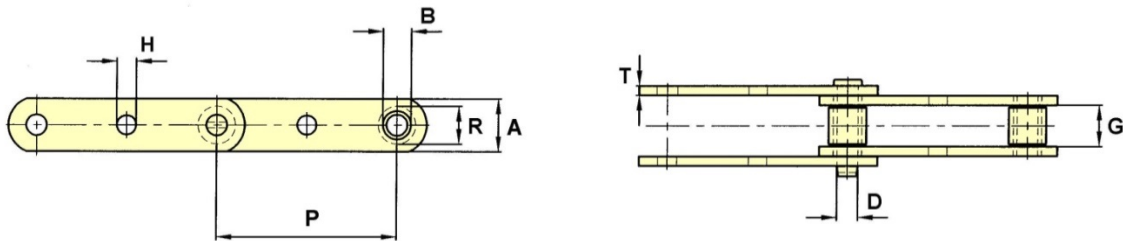

CHAIN NO.	PITCH P	ALLOW. LOAD	U.T.S.	PIN DIA. D	ROLLER DIA. R	SIDEBAR DEPTH A	MAX. GEARING G	BUSH DIA. B	BAR DIA. H	T
09060E	6.000	6,350	60,000	0.75	1.63	2.00	1.50	1.13	1.25	0.38
1796E	6.000	7,500	100,000	0.87	1.63	2.25	1.50	1.25	1.25	0.38
B5509E	9.000	7,500	100,000	0.87	1.63	2.25	1.50	1.25	1.25	0.38

* The tabular dimensions and weights are approximate and are not binding. Design improvements may result in variation from the published figures and verification is recommended.



Main & Auxiliary Cane Carrier Chains

Cane Carrier Roller Chains

A wide variety of cane carrier roller chains are available for selection. All are manufactured from high quality steel and heat treated to obtain the optimum characteristics of strength, and wear resistance

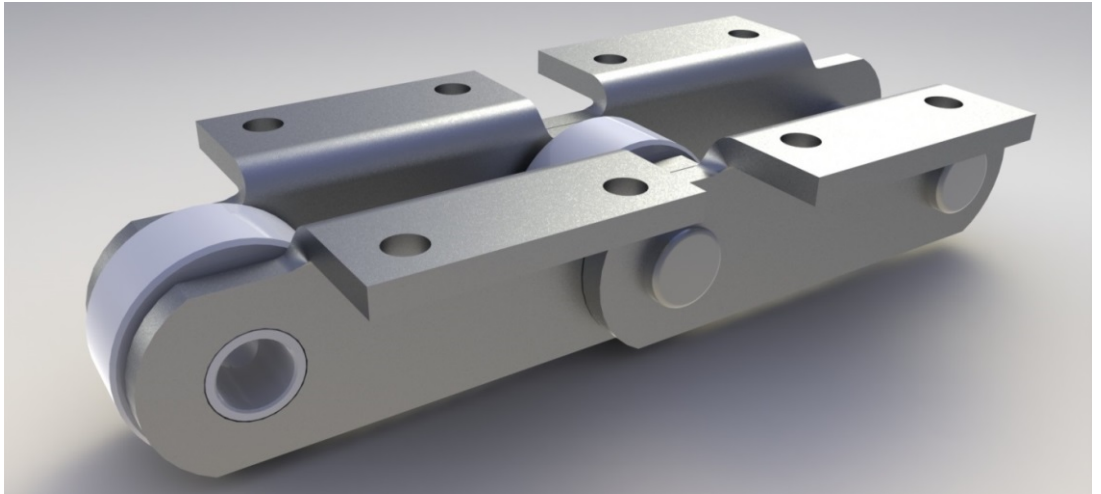

K2 Attachments

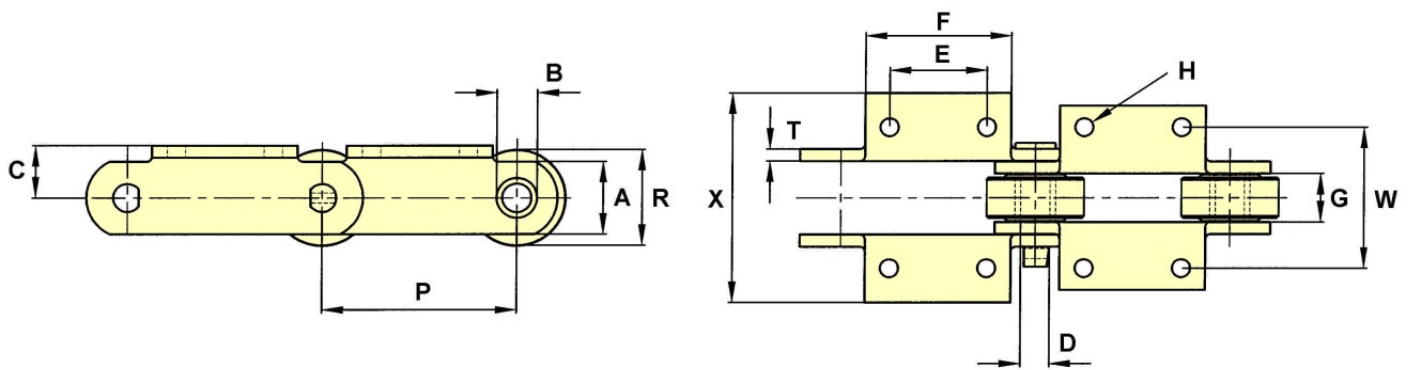



Main & Auxiliary Cane Carrier Chains

K2 Attachments

CHAIN NO.	PITCH P	ALLOW. LOAD	U.T.S.	Weight Lbs/ft	PIN DIA. D	ROLLER DIA. R	SIDEBAR DEPTH A	MAX. GEARING G	BUSH DIA. B	C	E	F	BOLT DIA. H	T	W	X
0904	4.00	4,850	40,000		0.69	2.00	1.75	1.22	1.00	1.25	1.44	2.63	0.38	0.31	3.50	4.13
B5257	6.00	5,375	50,000	13.9	0.69	3.00	1.75	1.44	1.00	1.63	2.36	4.00	0.55	0.31	4.72	7.13
09060	6.00	6,350	60,000	16.6	0.75	2.75	2.00	1.50	1.13	1.63	3.00	4.50	0.50	0.38	4.38	6.75
B5238	6.00	6,350	70,000		0.75	3.00	2.20	1.50	1.13	1.63	3.00	4.92	0.50	0.38	4.16	5.50
SS996	6.00	6,350	70,000	15.3	0.75	2.75	2.00	1.50	1.13	1.63	3.00	5.50	0.50	0.38	4.38	5.88
09061	6.00	6,350	85,000	17.0	0.75	2.75	2.25	1.50	1.13	1.63	3.00	4.50	0.50	0.38	4.38	6.50
B5259	6.00	6,300	100,000		0.75	3.00	2.00	1.50	1.13	1.63	2.36	4.50	0.55	0.38	4.72	6.75
B5255	6.00	7,450	100,000		0.88	3.00	2.25	1.69	1.25	1.63	2.36	4.50	0.50	0.38	4.92	6.40
1796	6.00	7,500	100,000	17.6	0.88	2.75	2.25	1.50	1.25	1.63	3.00	4.50	0.50	0.38	4.38	6.50
B5263	6.00	7,500	100,000		0.88	2.75	2.19	1.50	1.25	1.63	3.00	5.50	0.50	0.38	4.38	5.88
B5282	6.00	7,500	100,000		0.88	3.50	2.25	1.50	1.25	2.13	3.00	4.50	0.50	0.38	4.82	7.00
B5316	6.00	7,500	100,000		0.86	2.75	2.25	1.50	1.30	1.75	2.36	4.50	0.50	0.50	5.13	6.82
LB960	6.00	7,500	100,000		0.86	2.75	2.25	1.50	1.30	1.63	3.00	4.38	0.50	0.50	4.38	5.94
SS960	6.00	7,500	100,000	18.4	0.86	2.75	2.25	1.50	1.30	1.63	3.00	4.38	0.50	0.50	4.38	5.94
113	6.00	7,500	100,000	21.7	0.87	3.19	2.56	1.50	1.25	1.79	3.00	4.45	0.50	0.50	4.38	5.90
SS2198	6.00	7,650	100,000	18.8	0.88	2.75	2.25	1.50	1.25	1.63	3.00	4.50	0.50	0.50	4.38	5.94
B5310	6.00	8,300	100,000		0.88	3.00	2.25	1.75	1.38	1.63	2.63	4.50	0.50	0.38	4.92	6.75
A2198	6.00	8,400	100,000		0.87	3.00	2.38	1.53	1.25	1.69	3.00	4.38	0.50	0.50	4.38	5.88
B5260	6.00	10,200	130,000		0.97	3.38	2.81	2.19	1.38	1.84	2.20	3.69	0.50	0.38	6.10	5.13
B5284	6.00	7,350	138,000		0.94	3.00	2.44	1.50	1.31	1.75	3.00	4.50	0.50	0.38	4.38	6.50
2047	6.00	7,800	140,000	19.1	0.94	3.00	2.50	1.63	1.38	1.75	3.00	4.50	0.50	0.38	4.38	6.16
09063	6.00	8,300	140,000	18.5	0.94	3.00	2.38	1.50	1.25	1.75	3.00	4.50	0.50	0.41	4.38	6.50
B09063	6.00	8,300	140,000	18.5	0.94	3.00	2.38	1.50	1.43	1.75	3.00	4.50	0.50	0.41	4.38	6.50
B5293	6.00	8,300	140,000		0.94	3.00	2.44	1.50	1.25	1.75	3.00	4.50	0.50	0.41	4.38	6.50
09065	6.00	9,275	160,000	20.2	1.06	3.00	2.38	1.50	1.50	1.69	3.00	4.38	0.50	0.50	4.38	5.88
B5249	6.00	10,700	167,000		1.00	3.00	2.50	1.81	1.50	2.00	2.50	4.50	0.50	0.50	5.13	6.75
B5269	6.00	7,500	175,000		0.88	2.75	2.25	1.50	1.25	2.00	3.00	4.50	0.50	0.38	4.38	6.53
B5304	6.30	5,800	70,000		0.75	90MM	2.19	1.75	1.13	1.25	3.13	4.00	10MM	0.25	4.40	5.40
116	8.00	10,000	150,000	28.4	1.00	4.00	3.00	1.81	1.50	2.20	3.25	5.27	0.63	0.50	5.25	7.78
B5455	8.00	10,700	150,000	24.73	1.00	3.50	2.81	1.81	1.50	2.19	3.25	6.00	0.69	0.50	5.19	7.25
B5456	8.00	10,700	150,000		1.00	3.50	2.88	1.81	1.50	2.19	3.25	5.00	0.50	0.50	5.78	7.44
B5457	8.00	10,700	150,000	20.3	1.00	3.50	2.88	1.81	1.50	2.19	3.25	5.00	0.63	0.50	5.19	6.80
SS800R	8.00	10,700	167,000	27.2	1.00	3.50	2.81	1.81	1.50	2.19	4.50	2.00	0.63	0.50	5.19	7.25
2804	8.00	24,500	215,000	46.2	1.50	4.25	3.50	3.63	2.12	2.75	3.25	5.75	0.63	0.50	7.63	10.25
B5458	8.00	15,900	286,500	47.67	1.30	4.50	3.50	2.25	1.81	3.00	3.25	6.00	0.63	0.63	8.00	10.38
B5501	9.00	7,500	100,000		0.88	3.50	2.25	1.50	1.38	2.00	3.50	5.38	0.63	0.38	5.75	8.02
B5509	9.00	7,500	100,000		0.88	3.00	2.25	1.50	1.25	2.00	3.50	5.38	0.63	0.38	5.75	8.02
B5499	9.00	9,200	100,000	25.2	1.00	3.63	2.75	1.63	1.50	2.50	4.50	6.00	0.63	0.50	6.19	7.69
B5513	9.00	16,000	180,000		1.25	4.25	2.75	2.40	1.75	2.21	3.00	6.00	0.75	0.63	8.00	11.56
C2614	12.00	19,000	140,000		1.25	2.50	3.50	2.75	1.75	2.75	6.00	8.00	0.63	0.63	8.00	10.15
C2630	12.00	21,000	300,000		1.37	2.50	3.50	2.75	1.88	2.75	6.00	8.00	0.63	0.63	8.00	10.15

* The tabular dimensions and weights are approximate and are not binding. Design improvements may result in variation from the published figures and verification is recommended.



Main & Auxiliary Cane Carrier Chains

K2 Attachments

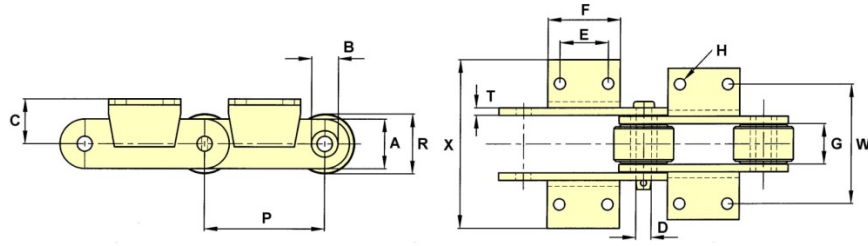

Note: Welded Angle Attachment.

CHAIN NO.	PITCH P	ALLOW. LOAD	U.T.S.	PIN DIA. D	ROLLER DIA. R	SIDEBAR DEPTH A	MAX. GEARING G	BUSH DIA. B	C	E	F	BOLT DIA. H	T	W	X
B5442	7.874	13,900	135,000	1.00	100MM	3.00	2.66	1.75	2.95	3.13	4.72	0.69	0.39	7.88	11.00

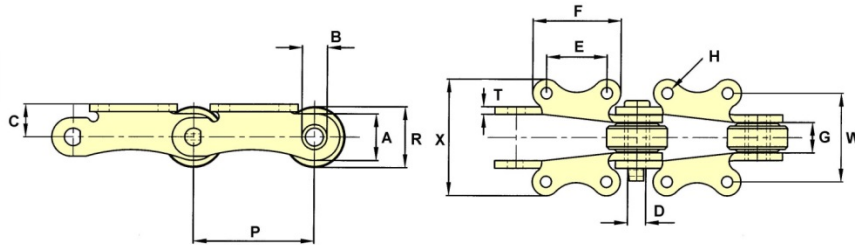

CHAIN NO.	PITCH P	ALLOW. LOAD	U.T.S.	Weight Lb/ft	PIN DIA. D	ROLLER DIA. R	SIDEBAR DEPTH A	MAX. GEARING G	BUSH DIA. B	C	E	F	BOLT DIA. H	T	W	X
SS600	6.000	7,500	100,000	14.0	0.88	2.75	2.30	1.50	1.25	1.63	3.00	4.38	0.50	0.38	4.38	5.75

K1 Attachment

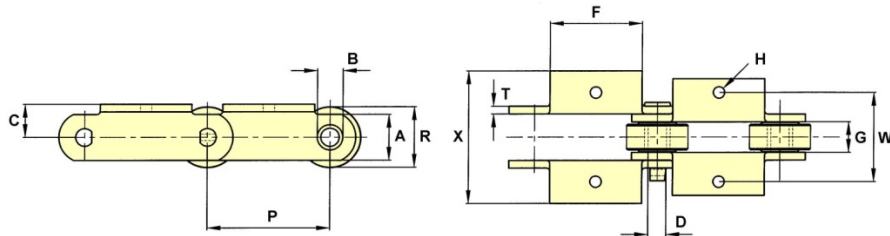

CHAIN NO.	PITCH P	ALLOW. LOAD	U.T.S.	PIN DIA. D	ROLLER DIA. R	SIDEBAR DEPTH A	MAX. GEARING G	BUSH DIA. B	C	F	BOLT DIA. H	T	W	X
B5044	3.00	2,100	13,000	0.43	1.50	1.12	1.00	0.64	0.81	2.00	0.38	0.19	2.94	3.88
B5041 #	3.00	3,885	25,000	0.55	1.75	1.50	1.50	0.80	1.50	2.00	0.50	0.25	4.40	6.38
B5093	4.00	4,850	40,000	0.69	2.25	1.75	1.22	1.00	1.25	2.63	0.50	0.31	4.00	6.00

= FLANGED ROLLER

* The tabular dimensions and weights are approximate and are not binding. Design improvements may result in variation from the published figures and verification is recommended.



Main & Auxiliary Cane Carrier Chains

K19 Attachment

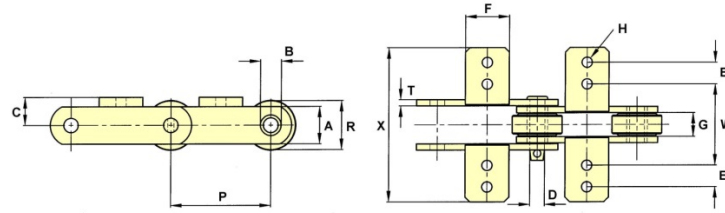

CHAIN NO.	PITCH P	ALLOW. LOAD	U.T.S.	PIN DIA. D	ROLLER DIA. R	SIDEBAR DEPTH A	MAX. GEARING G	BUSH DIA. B	C	E	F	BOLT DIA. H	T	W	X
B5057	3.937	4,300	50,000	0.62	3.00	1.75	1.06	0.91	1.13	0.87	1.75	0.38	0.38	3.62	6.53

K11 Attachment

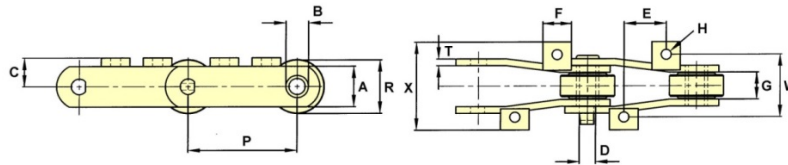

CHAIN NO.	PITCH P	ALLOW. LOAD	U.T.S.	PIN DIA. D	ROLLER DIA. R	SIDEBAR DEPTH A	MAX. GEARING G	BUSH DIA. B	C	E	F	BOLT DIA. H	T	W	X
B5276	6.05	5,900	60,000	0.75	2.63	2.00	1.38	1.13	1.47	2.31	1.57	0.50	0.38	3.50	4.90

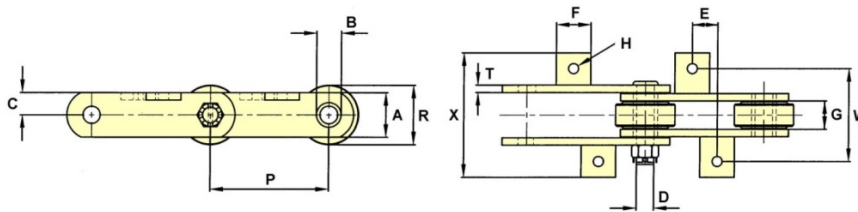

CHAIN NO.	PITCH P	ALLOW. LOAD	U.T.S.	PIN DIA. D	ROLLER DIA. R	SIDEBAR DEPTH A	MAX. GEARING G	BUSH DIA. B	C	E	F	BOLT DIA. H	T	W	X
B5286	6.00	8,700	100,000	1.02	75MM	2.38	1.69	1.43	1.19	1.28	1.75	0.50	0.38	4.88	6.19

Loop Link Attachment

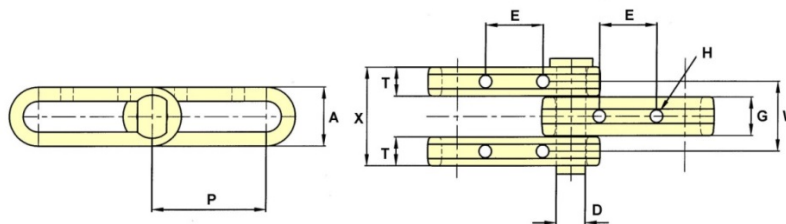

CHAIN NO.	PITCH P	ALLOW. LOAD	U.T.S.	PIN DIA. D	ROLLER DIA. R	SIDEBAR DEPTH A	MAX. GEARING G	BUSH DIA. B	E	BOLT DIA. H	T	W	X
B5291	6.000	11,600	320,000	1.53	-	3.06	2.00	-	3.00	0.63	1.50	3.56	5.06

* The tabular dimensions and weights are approximate and are not binding. Design improvements may result in variation from the published figures and verification is recommended.



Intermediate Carrier Roller Chains

When high loads dictate a stronger chain all steel roller versions will meet the need. Slat type carriers with K2 attachments or Scraper type with AS2 attachments shown here, both with stainless articulating parts will ensure trouble free intercarriers.

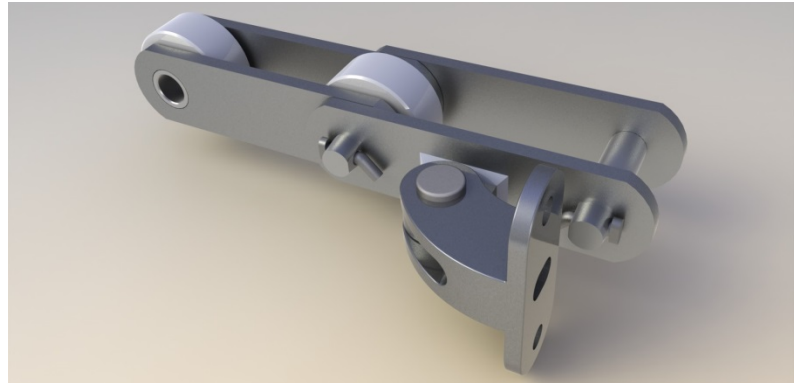

AS2 Attachments

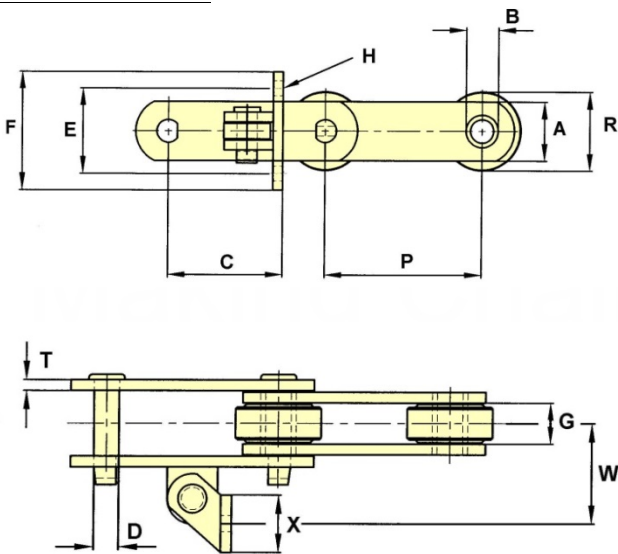

CHAIN NO.	PITCH P	ALLOW. LOAD	U.T.S.	Weight Lb/ft	PIN DIA. D	ROLLER DIA. R	SIDEBAR DEPTH A	MAX. GEARING G	BUSH DIA. B	C	E	F	BOLT DIA. H	T	W	X
0904	4.000	4,850	40,000		0.69	2.00	1.75	1.22	1.00	3.13	3.25	4.25	0.38	0.31	3.06	1.75
B5294	6.000	5,740	49,000		0.75	2.75	2.00	1.69	1.13	5.63	3.50	5.00	0.50	0.25	4.72	2.00
B5264	6.000	5,250	60,000		0.75	3.00	2.00	1.37	1.13	5.63	3.50	5.00	0.50	0.31	3.63	2.00
B5259	6.000	6,300	100,000		0.75	3.00	2.00	1.50	1.13	4.38	3.25	4.50	0.50	0.38	3.63	2.00
09060	6.000	6,350	60,000	11.2	15.5	0.75	2.75	2.00	1.13	4.38	3.25	4.50	0.50	0.38	3.50	2.00
D0906	6.000	6,350	60,000		0.75	2.75	2.00	1.50	1.13	4.38	3.25	4.50	0.50	0.38	3.50	2.00
09061	6.000	6,350	85,000	12.0	19.5	0.75	2.75	2.25	1.13	4.38	3.25	4.50	0.50	0.38	3.50	2.00
1796	6.000	7,500	100,000	12.6	17.5	0.87	2.75	2.25	1.25	4.38	3.25	4.50	0.50	0.38	3.50	2.00
B5269	6.000	7,500	175,000		0.87	2.75	2.25	1.50	1.25	5.63	3.50	5.00	0.50	0.38	3.75	2.00
SS2198	6.000	7,650	100,000		0.87	2.75	2.25	1.50	1.25	5.63	3.50	5.00	0.50	0.50	3.88	2.00
B5293	6.000	8,300	140,000		0.94	3.00	2.44	1.50	1.25	5.63	3.50	5.00	0.50	0.41	3.94	2.00
09063	6.000	8,300	140,000	15.2	20.8	0.94	3.00	2.38	1.25	5.63	3.50	5.00	0.50	0.41	3.94	2.00
A2198	6.000	8,400	100,000		0.87	3.00	2.38	1.53	1.25	5.63	3.50	5.00	0.50	0.50	3.91	2.00
B5256	6.000	8,970	117,000		1.00	75MM	2.50	1.81	1.50	5.56	5.50	7.25	0.75	0.38	3.63	2.36
09065	6.000	9,275	160,000		1.06	3.00	2.38	1.50	1.50	4.38	3.31	4.50	0.50	0.50	3.61	1.94
B5276	6.050	5,900	60,000		0.75	2.63	2.00	1.38	1.13	4.40	3.25	4.50	0.50	0.38	3.38	2.00
B5267	6.060	7,200	50,000		1.00	3.00	2.25	1.31	1.50	4.41	3.25	4.50	0.50	0.38	3.41	2.00
B5509	9.000	7,500	100,000		0.87	3.00	2.25	1.50	1.25	7.13	3.50	5.00	0.50	0.38	4.12	2.00

* The tabular dimensions and weights are approximate and are not binding. Design improvements may result in variation from the published figures and verification is recommended.



Intermediate Carrier Chains

AS2 Attachments

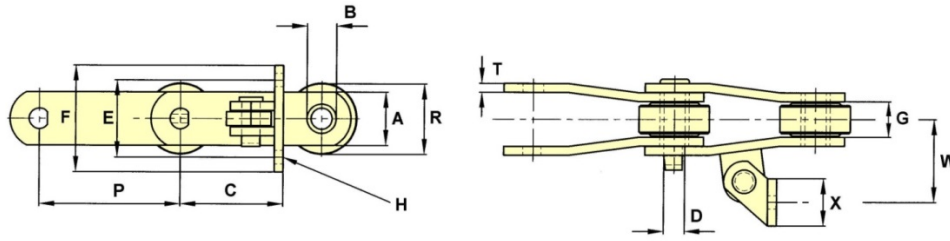

CHAIN NO.	PITCH P	ALLOW. LOAD	U.T.S.	Weight Lb/ft		PIN DIA. D	ROLLER DIA. R	SIDEBAR DEPTH A	MAX. GEARING G	BUSH DIA. B	C	E	F	BOLT DIA. H	T	W	X
				Plain	AS2												
09060	6.000	6,350	60,000	11.2	15.2	0.75	2.75	2.00	1.50	1.13	4.38	3.25	4.50	0.50	0.38	3.50	2.00
09061	6.000	6,350	85,000	12.0	19.5	0.75	2.75	2.25	1.50	1.13	4.38	3.25	4.50	0.50	0.38	3.50	2.00
B5280	6.000	6,700	55,000			0.87	3.00	2.00	1.44	1.25	5.63	3.50	5.00	0.50	0.38	3.63	2.00
B5234	6.000	7,100	80,000			0.87	3.00	2.00	1.37	1.25	5.63	3.50	5.00	0.50	0.38	3.63	2.00
B5311	6.000	7,100	80,000			0.87	3.00	2.00	1.38	1.25	5.63	3.50	5.00	0.50	0.38	3.63	2.00
D2184	6.000	7,100	80,000	11.7	16.2	0.87	3.00	2.00	1.38	1.25	5.63	3.50	5.00	0.50	0.38	3.63	2.00
DN2184	6.000	7,100	80,000	12.3	17.9	0.87	3.00	2.00	1.38	1.25	5.63	3.50	5.00	0.50	0.38	3.63	2.00
1796	6.000	7,500	100,000	12.6	17.5	0.87	2.75	2.25	1.50	1.25	4.38	3.25	4.50	0.50	0.38	3.50	2.00
SS2198	6.000	7,650	100,000			0.87	2.75	2.25	1.50	1.25	5.63	3.50	5.00	0.50	0.50	3.88	2.00
09063	6.000	8,300	140,000	15.2	20.8	0.94	3.00	2.38	1.50	1.25	5.63	3.50	5.00	0.50	0.41	3.94	2.00
9184	6.000	8,500	175,000			0.94	3.00	2.50	1.56	1.38	5.63	3.50	5.00	0.50	0.50	3.91	2.00
9185	6.000	8,500	175,000			0.94	3.50	2.50	1.56	1.38	5.63	3.50	5.00	0.50	0.50	3.91	2.00
F9184	6.000	8,500	175,000			0.94	3.00	2.50	1.56	1.38	5.63	3.50	5.00	0.50	0.50	3.91	2.00
SS2186	6.000	9,500	175,000			1.00	3.50	2.50	1.50	1.38	5.63	3.50	5.00	0.50	0.50	3.63	2.00
B5313	6.000	10,550	140,000			1.16	3.00	2.50	1.58	1.50	5.63	3.50	5.00	0.50	0.50	4.00	2.00
B5276	6.050	5,900	60,000			0.75	2.63	2.00	1.38	1.00	4.40	3.25	4.50	0.50	0.38	3.38	2.00
326	8.000	10,000	150,000	22.7	37.4	1.00	4.00	80mm	2.88	1.50	7.28	4.72	6.89	0.63	0.50	5.51	2.36
8184	8.000	10,700	167,000	19.0	23.9	1.00	3.50	2.75	1.81	1.50	6.63	3.50	5.00	0.50	0.50	4.22	2.00

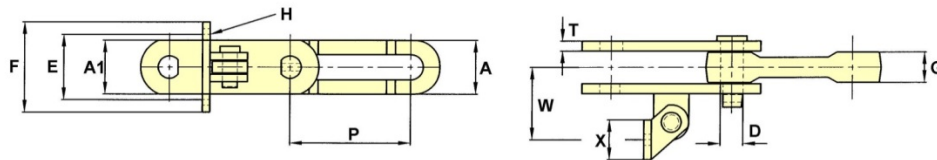

CHAIN NO.	PITCH P	ALLOW. LOAD	U.T.S.	PIN DIA. D	INNER SIDE DEPTH A	OUTER SIDE DEPTH A1	MAX. GEARING G	E	F	BOLT DIA. H	T	W	X
B5283	6.031	6,400	136,000	1.12	2.50	2.69	1.63	3.25	4.50	0.50	0.50	3.63	2.00

* The tabular dimensions and weights are approximate and are not binding. Design improvements may result in variation from the published figures and verification is recommended.



Intermediate Carrier Chains

Due to the severity of corrosive attack on rotating chain parts, Ewart have developed a range of chains to meet these conditions. A selection of which are shown below.

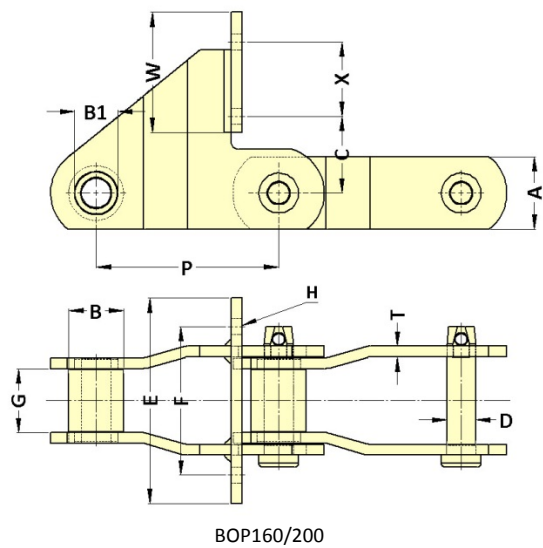
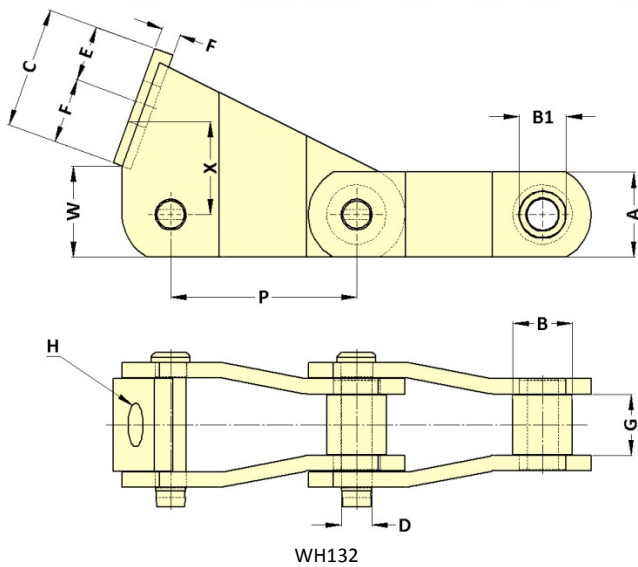
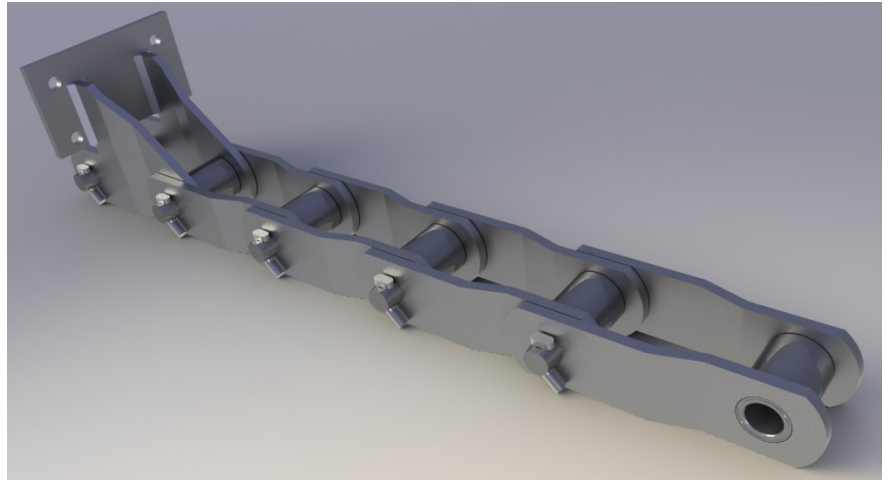

CHAIN	PITCH	ALLOW LOAD	UTS	Weight / Ft		Pin Dia D	Sidebar Depth A	Max Gear G	Bush Dia B	Bush Neck B1	C	E	F	Bolt Dia H	T	W	X
				Lbs Plain	Lbs Attach												
WH132	6.050	11,000	150,000	7.76	13.3	1.00	2.75	2.00	1.93	1.54	3.94	1.81	0.62	1.42	0.50	2.95	3.015
BOP160	6.299	10,300	100,000	6	10.9	1.00	2.50	2.20	1.89	1.49	2.65	7.08	5.12	0.55	0.38	4.13	2.56
BOP200	7.874	10,300	100,000	5	9	1.00	2.50	2.20	1.89	1.49	2.65	7.08	5.12	0.55	0.38	4.13	2.56

* The tabular dimensions and weights are approximate and are not binding. Design improvements may result in variation from the published figures and verification is recommended.



Intermediate Carrier Chains

Pusher Type

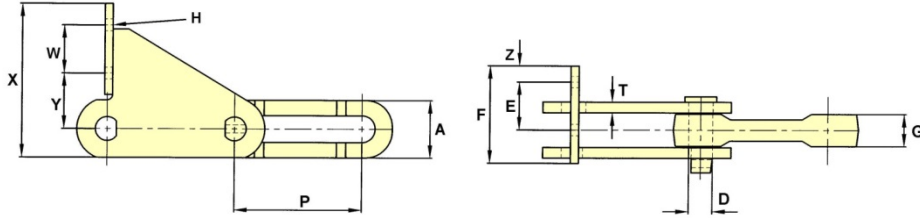

CHAIN NO.	PITCH P	ALLOW. LOAD	U.T.S.	PIN DIA. D	SIDEBAR DEPTH A	MAX. GEARING G	E	F	BOLT DIA. H	T	W	X	Y	Z
B5283	6.031	6,400	136,000	1.12	2.69	1.63	2.25	4.56	0.50	0.50	2.25	7.19	2.60	0.75

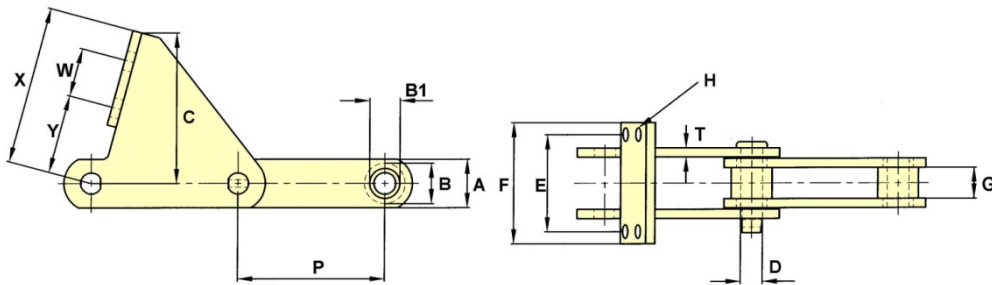

CHAIN NO.	PITCH P	ALLOW. LOAD	U.T.S.	PIN DIA. D	S/ BAR DEPTH A	MAX. GEAR G	BUSH DIA. B	BUSH NECK B1	C	E	F	BOLT DIA. H	T	W	X	Y
1796#	6.000	7,500	100,000	0.87	2.25	1.50	1.75	1.25	3.88	120MM	160MM	12MM	0.38	50MM	5.06	2.11
D2184	6.000	7,100	80,000	0.87	2.00	1.38	1.25	-	6.28	4.00	5.00	0.50	0.38	2.00	6.50	3.25

PUSHER FACES ARE VERTICAL

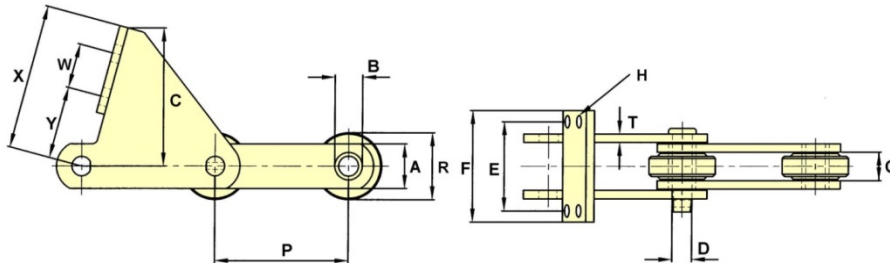

CHAIN NO.	PITCH P	ALLOW. LOAD	U.T.S.	PIN DIA. D	ROLLER DIA. R	S/BAR DEPTH A	MAX. GEAR G	BUSH DIA. B	C	E	F	BOLT DIA. H	T	W	X	Y
2084	6.000	7,300	100,000	0.87	3.00	2.00	1.38	1.25	5.06	2.38	5.50	0.56	0.50	1.81	5.56	2.00
D2184	6.000	7,100	80,000	0.87	3.00	2.00	1.38	1.25	5.00	4.75	6.25	0.50	0.38	2.19	5.69	2.13
D2184	6.000	7,100	80,000	0.87	3.00	2.00	1.38	1.25	6.28	4.00	5.00	0.50	0.38	2.00	6.50	3.25
D2184	6.000	7,100	80,000	0.87	3.00	2.00	1.38	1.25	6.28	3.63	5.00	0.44	0.38	3.50	7.50	3.25

* The tabular dimensions and weights are approximate and are not binding. Design improvements may result in variation from the published figures and verification is recommended.



Intermediate Carrier Chains

Pusher Type

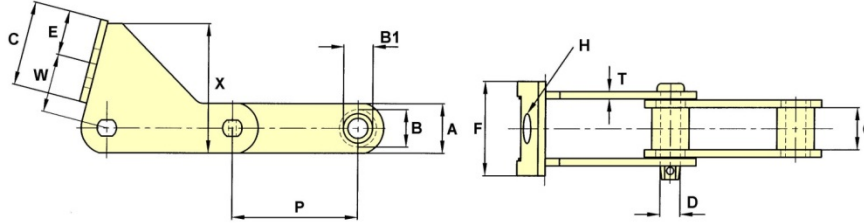

CHAIN NO.	PITCH P	ALLOW. LOAD	U.T.S.	PIN DIA. D	SIDEBAR DEPTH A	MAX. GEAR G	BUSH DIA. B	BUSH NECK B1	C	E	F	BOLT DIA H	T	W	X
E160	160MM	10,300	100,000	1.00	2.25	2.20	48MM	1.50	4.25	2.25	4.75	1.50	0.38	2.93	6.50
EC160A	160MM	10,300	100,000	1.00	2.25	2.20	48MM	1.50	4.25	2.25	4.75	1.50	0.38	2.93	6.50
506	6.050	10,330	170,000	1.00	2.75	1.94	48MM	1.50	3.75	1.75	3.75	36MM	0.50	3.00	6.00

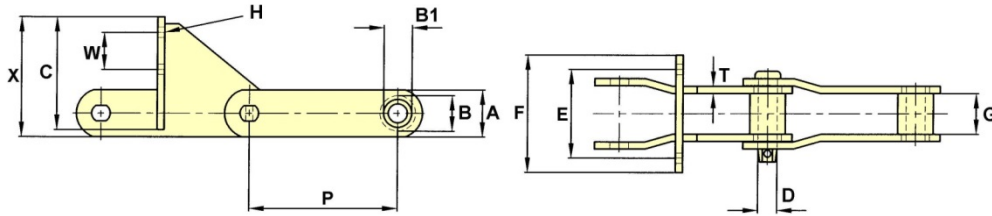

CHAIN NO.	PITCH P	ALLOW. LOAD	U.T.S.	PIN DIA. D	SIDEBAR DEPTH A	MAX. GEAR G	BUSH DIA. B	BUSH NECK B1	C	E	F	BOLT DIA H	T	W	X
EC160A	160MM	10,300	100,000	1.00	2.50	2.20	48MM	1.50	3.50	108MM	140MM	12MM	0.38	50MM	6.33
EC160A	160MM	10,300	100,000	1.00	2.50	2.20	48MM	1.50	3.50	120MM	160MM	12MM	0.38	50MM	6.33
EC200	200MM	10,300	100,000	1.00	2.50	2.20	48MM	1.50	6.00	120MM	6.25	12MM	0.38	50MM	6.38

* The tabular dimensions and weights are approximate and are not binding. Design improvements may result in variation from the published figures and verification is recommended.



Intermediate Carrier Chains

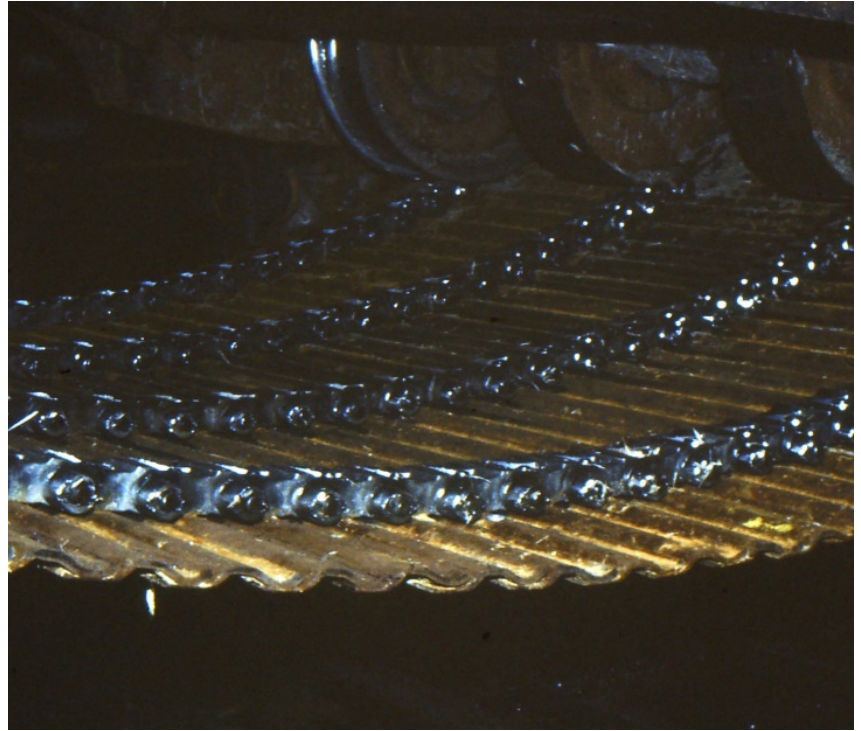
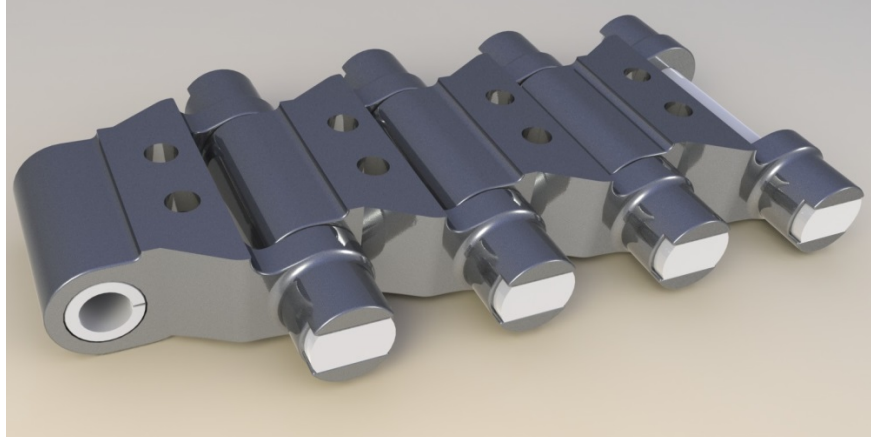
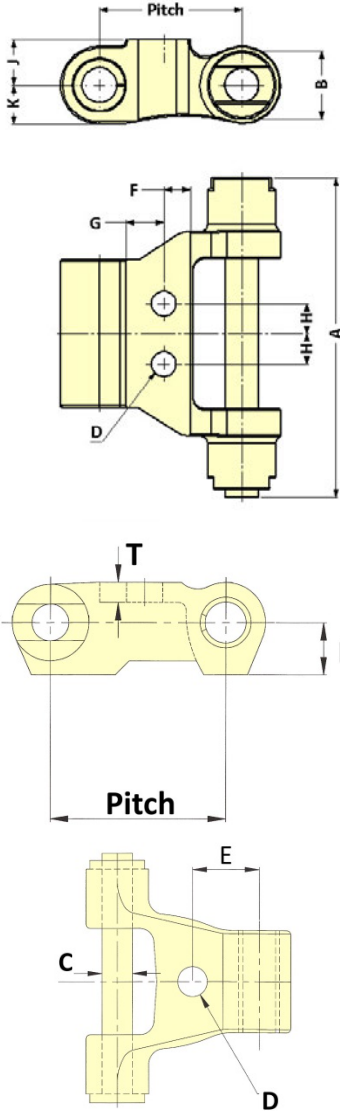

This range of chains has been developed to combat the extreme corrosion created by continuous operation in raw sugar juice.

For increased resistance to corrosion Stainless Steel articulating components are available.

Where severe conditions are encountered all these chains are available in a Stainless Steel material.

Chain	Pitch	Style	Allowable Chain Pull Lb	Breaking Load		Weight Lb/Ft	A	B	C	D [^]	E	F	G	H	J	K	L	T
				Lb	Kg													
5174E4	2.36	A	3,290	22,500	10,215	11.7	5.5	1.13	0.53	0.38	1.06	0.44	0.63	0.5	0.75	0.66	-	0.31
901E41 E43	3.15	B	4,200	30,000	13,620	12.5	5.75	1.34	0.63	0.63 0.38	1.75	0.59	0.78	- 0.56	0.78	-	0.94	0.36
901E42 E44	3.15	B	4,200	30,000	13,620	12.5	5.75	1.34	0.63	0.63 0.38	1.56	0.66	0.59	- 0.56	0.78	-	0.94	0.36
907E51	3.17	B	4,200	35,000	15,890	13.4	5.75	1.41	0.63	0.63	1.5	0.69	0.69	-	0.72	-	0.94	0.36

D[^] = Bolt diameter

* The tabular dimensions and weights are approximate and are not binding. Design improvements may result in variation from the published figures and verification is recommended.



Intermediate Carrier Chains

K2 Attachments

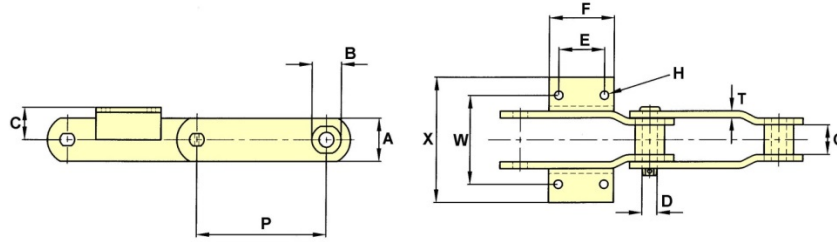

CHAIN NO.	PITCH P	ALLOW. LOAD	U.T.S.	PIN DIA. D	SIDEBAR DEPTH A	MAX. GEARING G	BUSH DIA. B	C	E	F	BOLT DIA. H	T	W	X
C69A	12.000	21,000	300,000	1.38	4.00	2.75	2.75	3.00	4.21	6.00	18MM	0.63	8.25	11.22
C84	9.000	17,500	250,000	1.25	3.25	2.87	2.50	3.00	3.00	4.50	16MM	0.56	8.25	11.09

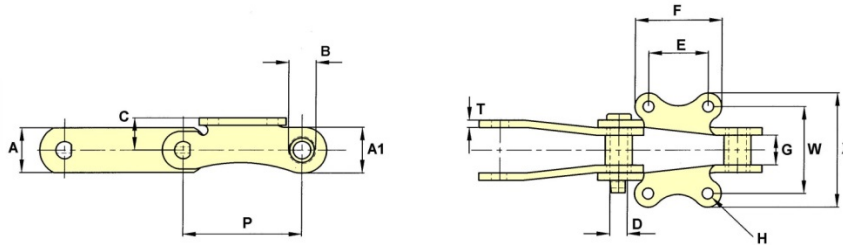

CHAIN NO.	PITCH P	ALLOW. LOAD	U.T.S.	PIN DIA. D	PLAIN SIDEBAR DEPTH A	ATTACH. SIDEBAR DEPTH A1	MAX. GEARING G	BUSH DIA. B	C	E	F	BOLT DIA. H	T	W	X
B5252	6.000	7,500	100,000	0.87	2.25	2.30	1.50	1.38	1.63	3.00	4.38	0.50	0.38	4.38	5.75

F TYPE Attachments

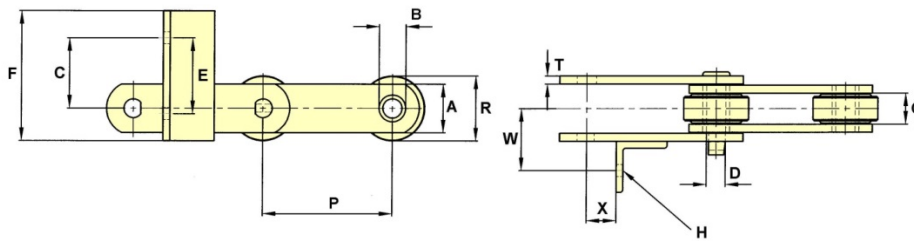

CHAIN NO.	PITCH P	ALLOW. LOAD	U.T.S.	PIN DIA. D	ROLLER DIA. R	SIDEBAR DEPTH A	MAX. GEARING G	BUSH DIA. B	C	E	F	BOLT DIA. H	T	W	X
B5278	6.000	7,650	77,000	0.94	3.50	2.50	1.56	1.25	3.25	3.50	6.00	12MM	0.38	2.87	1.38

* The tabular dimensions and weights are approximate and are not binding. Design improvements may result in variation from the published figures and verification is recommended.



Intermediate Carrier Chains

F TYPE Attachments

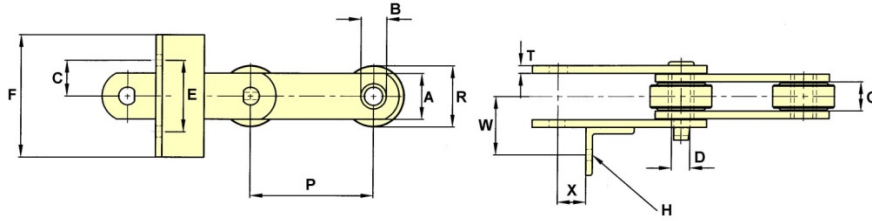

CHAIN NO.	PITCH P	ALLOW. LOAD	U.T.S.	PIN DIA. D	ROLLER DIA. R	SIDEBAR DEPTH A	MAX. GEARING G	BUSH DIA. B	C	E	F	BOLT DIA. H	T	W	X
B5461	8.000	3,300	150,000	0.75	1.88	1.50	0.75	0.92	1.13	2.25	3.38	10MM	0.25	1.75	3.00

LUG Only Attachments

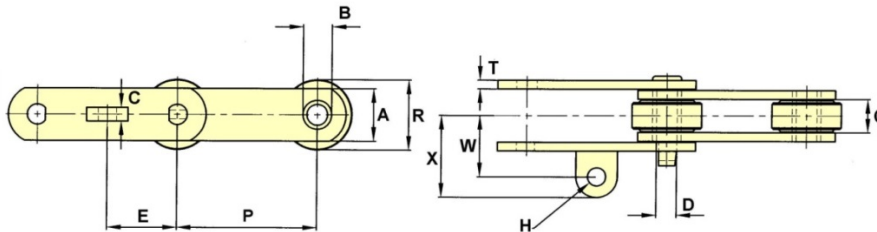

CHAIN NO.	PITCH P	ALLOW. LOAD	U.T.S.	PIN DIA. D	ROLLER DIA. R	SIDEBAR DEPTH A	MAX. GEARING G	BUSH DIA. B	C	E	BOLT DIA. H	T	W	X
B5262	6.000	6,600	100,000	0.75	2.75	2.00	1.56	1.13	15MM	3.00	0.63	0.38	2.75	3.73
B5273	6.000	7,650	70,500	0.88	2.75	60MM	1.51	1.38	30MM	3.00	0.75	10MM	2.89	3.83
B5294	6.000	5,740	49,000	0.75	2.75	2.00	1.69	1.13	12MM	3.00	18MM	0.25	3.53	4.39

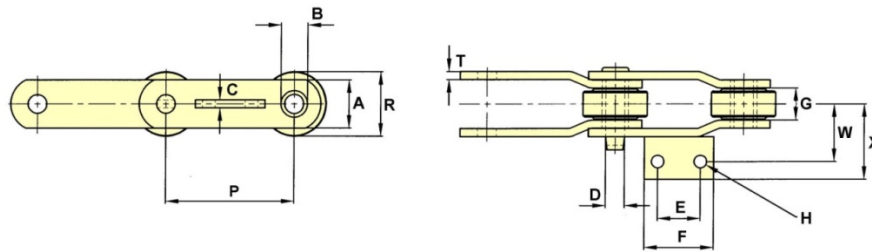

CHAIN NO.	PITCH P	ALLOW. LOAD	U.T.S.	PIN DIA. D	ROLLER DIA. R	SIDEBAR DEPTH A	MAX. GEARING G	BUSH DIA. B	C	E	F	BOLT DIA. H	T	W	X
B5261	6.000	7,100	80,000	0.88	3.00	2.00	1.37	1.25	0.38	2.00	3.25	14MM	0.38	2.63	3.45
B5297	6.000	7,100	80,000	0.88	3.00	2.00	1.37	1.25	12MM	3.00	4.50	0.63	0.38	3.00	3.82

* The tabular dimensions and weights are approximate and are not binding. Design improvements may result in variation from the published figures and verification is recommended.



Intermediate Carrier Chains

LUG Only Attachments

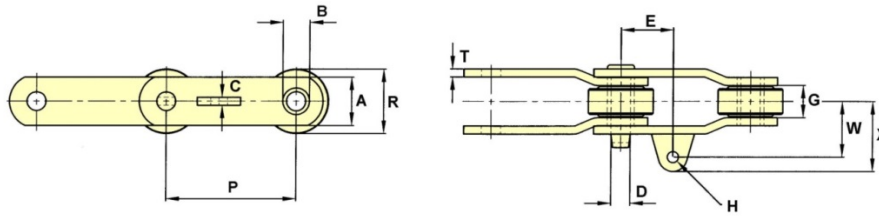

CHAIN NO.	PITCH P	ALLOW. LOAD	U.T.S.	PIN DIA. D	ROLLER DIA. R	SIDEBAR DEPTH A	MAX. GEARING G	BUSH DIA. B	C	E	BOLT DIA H	T	W	X
B5515	9.000	8,500	120,000	1.00	3.50	2.25	1.50	1.50	15MM	4.50	0.75	0.38	3.12	4.12

Forged Block Link

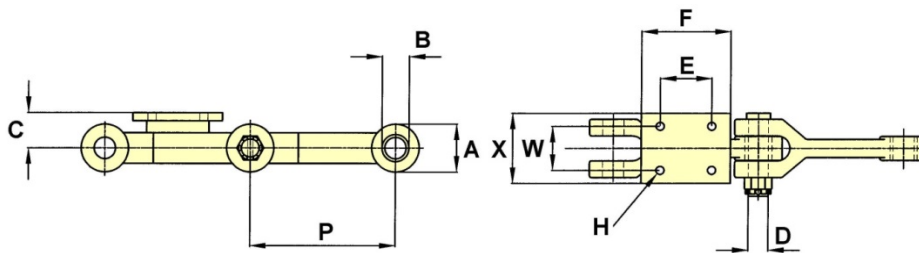

CHAIN NO.	PITCH P	ALLOW. LOAD	U.T.S.	PIN DIA. D	SIDEBAR DEPTH A	BUSH DIA. B	C	E	F	BOLT DIA H	W	X
E229	9.000		135,000	35MM	60MM	41MM	53MM	70MM	105MM	16MM	85MM	120MM
E305	12.000		194,000	45MM	100MM	57MM	74MM	108MM	187MM	16MM	92MM	127MM

Forged Rivetless

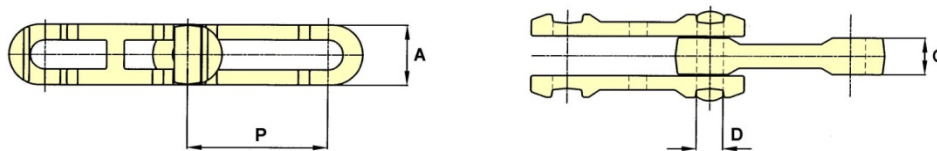

CHAIN NO.	PITCH P	ALLOW. LOAD	U.T.S.	PIN DIA. D	SIDEBAR DEPTH A	MAX. GEARING G
348	3.031	2,400	24,000	0.50	1.13	0.74
458	4.031	3,000	48,000	0.62	1.38	1.06
468	4.031	7,000	68,000	0.75	1.88	1.81
678	6.031	8,500	85,000	0.87	2.00	1.25
698	6.031	13,000	136,000	1.10	2.53	1.53
698HD	6.031	13,000	136,000	1.10	2.69	1.53
998	9.031	13,000	136,000	1.10	2.66	1.53
9118	9.031		220,000	16.0	1.38	2.00

* The tabular dimensions and weights are approximate and are not binding. Design improvements may result in variation from the published figures and verification is recommended.



Intermediate Carrier Chains

Bar Link Chains

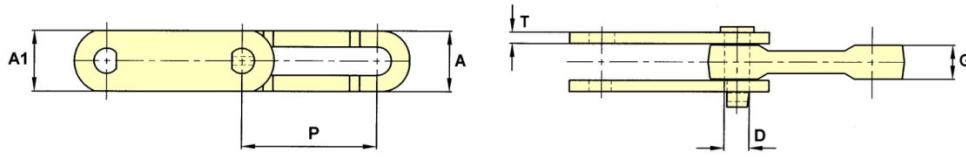

CHAIN NO.	PITCH P	ALLOW. LOAD	U.T.S.	PIN DIA. D	INNER SIDE DEPTH A	OUT. SIDE DEPTH A1	MAX. GEARING G	T
S3699	6.031	6,000	130,000	1.12	2.50	2.88	1.56	0.50
B5283	6.031	6,400	136,000	1.12	2.50	2.69	1.63	0.50

Cast Pintle F29 Type

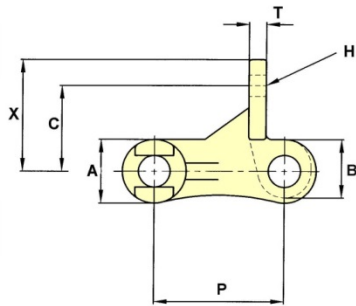

4103 F29

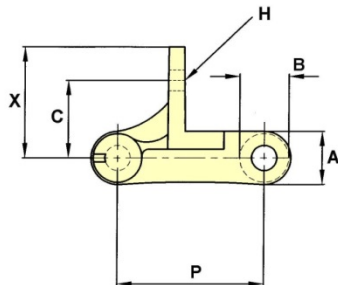
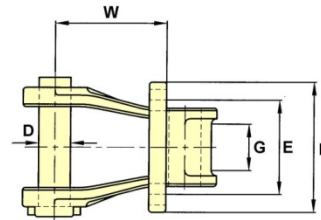

488 F2

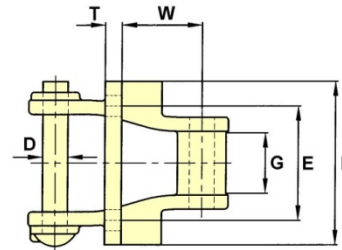

CHAIN NO.	PITCH P	ALLOW. LOAD	U.T.S.	PIN DIA. D	B	C	E	F	BOLT DIA. H	T	W	X
4103F29	3.075	3,500	22,000	0.75	1.25	2.00	3.22	3.28	0.50	0.44	2.64	2.64
488F2	2.609	1,800	11,000	0.44	0.87	1.38	2.03	2.91	0.31	0.28	1.42	1.97

* The tabular dimensions and weights are approximate and are not binding. Design improvements may result in variation from the published figures and verification is recommended.



Bagasse Elevator & Conveyor Chains

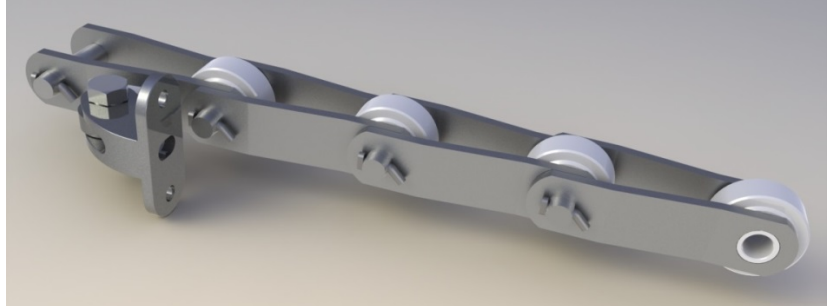

A wide variety of Bagasse Conveyor Roller Chains are available for selection. All are manufactured from high quality steel and heat treated to obtain optimum characteristics of strength and wear resistance.



AS2 Attachments

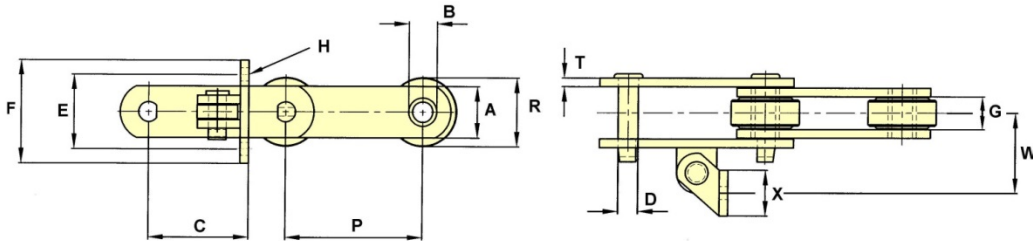

CHAIN NO.	PITCH P	ALLOW. LOAD	U.T.S.	Weight Lb/ft		PIN DIA. D	ROLLER DIA. R	SIDEBAR DEPTH A	MAX. GEARING G	BUSH DIA. B	C	E	F	BOLT DIA. H	T	W	X
				Plain	AS2												
0904	4.000	4,850	40,000			0.69	2.00	1.75	1.22	1.00	3.13	3.25	4.25	0.38	0.31	3.06	1.75
B5264	6.000	5,250	60,000			0.75	3.00	2.00	1.37	1.13	5.63	3.50	5.00	0.50	0.31	3.63	2.00
09060	6.000	6,350	60,000	11.2	15.5	0.75	2.75	2.00	1.50	1.13	4.38	3.25	4.50	0.50	0.38	3.50	2.00
D0906	6.000	6,350	60,000			0.75	2.75	2.00	1.50	1.13	4.38	3.25	4.50	0.50	0.38	3.50	2.00
EC1131	6.000	6,350	60,000	11.2	15.5	0.75	2.75	2.00	1.50	1.13	4.38	3.25	4.50	0.50	0.38	3.50	2.00
09061	6.000	6,350	85,000	12.0	19.5	0.75	2.25	2.25	1.50	1.13	4.38	3.25	4.50	0.50	0.38	3.50	2.00
B5259	6.000	6,300	100,000			0.75	3.00	2.00	1.50	1.13	4.38	3.25	4.50	0.50	0.38	3.63	2.00
B5269	6.000	7,500	175,000			0.87	2.75	2.25	1.50	1.25	5.63	3.50	5.00	0.50	0.38	3.75	2.00
SS2198	6.000	7,650	100,000			0.87	2.75	2.25	1.50	1.25	5.63	3.50	5.00	0.50	0.50	3.88	2.00
B5293	6.000	8,300	140,000			0.94	3.00	2.44	1.50	1.25	5.63	3.50	5.00	0.50	0.41	3.94	2.00
09063	6.000	8,300	140,000	15.2	20.8	0.94	3.00	2.38	1.50	1.25	5.63	3.50	5.00	0.50	0.41	3.94	2.00
A2198	6.000	8,400	100,000			0.87	3.00	2.38	1.53	1.25	5.63	3.50	5.00	0.50	0.50	3.91	2.00
B5256	6.000	8,970	117,000			1.00	75MM	2.50	1.81	1.50	5.56	5.50	7.25	0.75	0.38	3.63	2.36
09065	6.000	9,275	160,000			1.06	3.00	2.38	1.50	1.50	4.38	3.31	4.50	12MM	0.50	3.61	50MM
2600	6.000	11,900	160,000			1.00	3.50	3.00	2.65	1.49	5.75	3.50	5.00	0.50	0.38	4.75	2.00
B5276	6.050	5,900	60,000			0.75	2.63	2.00	1.38	1.13	4.40	3.25	4.50	0.5	0.38	3.38	2.00
B5267	6.060	7,200	50,000			1.00	3.00	2.25	1.31	1.50	4.41	3.25	4.50	0.50	0.38	3.41	2.00
B5509	9.000	7,500	100,000			0.87	3.00	2.25	1.50	1.25	7.13	3.50	5.00	0.50	0.38	4.12	2.00

* The tabular dimensions and weights are approximate and are not binding. Design improvements may result in variation from the published figures and verification is recommended.



Bagasse Elevator & Conveyor Chains

AS2 Attachments

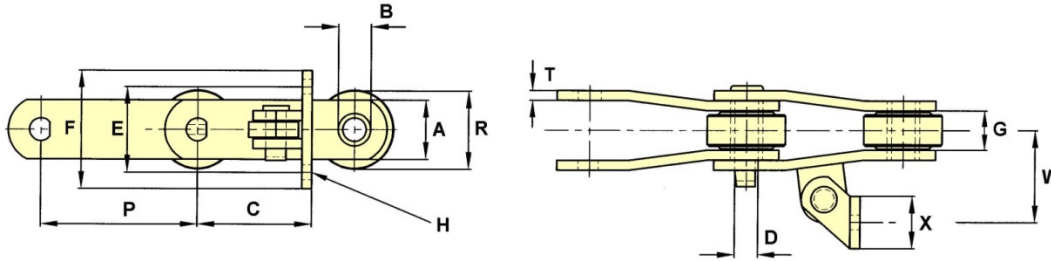

CHAIN NO.	PITCH P	ALLOW. LOAD	U.T.S.	Weight Lb/ft		PIN DIA. D	ROLLER DIA. R	SIDEBAR DEPTH A	MAX. GEARING G	BUSH DIA. B	C	E	F	BOLT DIA. H	T	W	X
				Plain	AS2												
0904	4.000	4,850	40,000			0.69	2.00	1.75	1.22	1.00	3.13	3.25	4.25	0.38	0.31	3.06	1.75
B5096	4.020	4,685	35,000			0.69	2.00	1.50	1.31	1.00	3.13	3.25	4.25	0.38	0.31	2.75	1.75
09060	6.000	6,350	60,000	11.2	15.2	0.75	2.75	2.00	1.50	1.13	4.38	3.25	4.50	0.50	0.38	3.50	2.00
B5276	6.050	5,900	60,000			0.75	2.63	2.00	1.38	1.00	4.40	3.25	4.50	0.50	0.38	3.38	2.00
09061	6.000	6,350	85,000	12.0	19.5	0.75	2.75	2.25	1.50	1.13	4.38	3.25	4.50	0.50	0.38	3.50	2.00
B5280	6.000	6,700	55,000			0.87	3.00	2.00	1.44	1.25	5.63	3.50	5.00	0.50	0.38	3.63	2.00
B5234	6.000	7,100	80,000			0.87	3.00	2.00	1.37	1.25	5.63	3.50	5.00	0.50	0.38	3.63	2.00
B5311	6.000	7,100	80,000			0.87	3.00	2.00	1.38	1.25	5.63	3.50	5.00	0.50	0.38	3.63	2.00
D2184	6.000	7,100	80,000	12.3	17.9	0.87	3.00	2.00	1.38	1.25	5.63	3.50	5.00	0.50	0.38	3.63	2.00
ET2184*	6.000	7,100	80,000			0.87	3.00	2.00	1.38	1.25	5.63	3.50	5.00	0.50	0.38	3.63	2.00
DN2184	6.000	7,100	80,000	12.6	17.5	0.87	3.00	2.00	1.38	1.25	5.63	3.50	5.00	0.50	0.38	3.63	2.00
1796	6.000	7,500	100,000	12.6	17.5	0.87	2.75	2.25	1.50	1.25	4.38	3.25	4.50	0.50	0.38	3.50	2.00
SS2198	6.000	7,650	100,000			0.87	2.75	2.25	1.50	1.25	5.63	3.50	5.00	0.50	0.50	3.88	2.00
09063	6.000	8,300	140,000	15.2	20.8	0.94	3.00	2.38	1.50	1.25	5.63	3.50	5.00	0.50	0.41	3.94	2.00
5184	6.000	10,000	160,000			1.10	3.00	2.50	2.33	1.49	5.63	3.50	5.00	0.50	0.50	3.82	2.00
9184	6.000	8,500	175,000			0.94	3.00	2.50	1.56	1.38	5.63	3.50	5.00	0.50	0.50	3.91	2.00
9185	6.000	8,500	175,000			0.94	3.50	2.50	1.56	1.38	5.63	3.50	5.00	0.50	0.50	3.91	2.00
F9184	6.000	8,500	175,000			0.94	3.00	2.50	1.56	1.38	5.63	3.50	5.00	0.50	0.50	3.91	2.00
SS2186	6.000	9,500	175,000			1.00	3.50	2.50	1.50	1.38	5.63	3.50	5.00	0.50	0.50	3.63	2.00
B5313	6.000	10,550	140,000			1.16	3.00	2.50	1.58	1.50	5.63	3.50	5.00	0.50	0.50	4.00	2.00
8184	8.000	10,700	167,000	19.0	23.9	1.00	3.50	2.75	1.81	1.50	6.63	3.50	5.00	0.50	0.50	4.22	2.00
326	8.000	10,000	150,000	22.7	37.4	1.00	4.00	80mm	2.88	1.50	7.28	4.72	6.89	0.63	0.50	5.51	2.36
B5509	9.000	7,500	100,000			0.87	3.50	2.25	1.50	1.25	7.13	3.50	5.00	0.50	0.38	4.12	2.00

* ET2184 is a cranked flat design sidebar.

* The tabular dimensions and weights are approximate and are not binding. Design improvements may result in variation from the published figures and verification is recommended.



Bagasse Elevator & Conveyor Chains

F Type Attachments

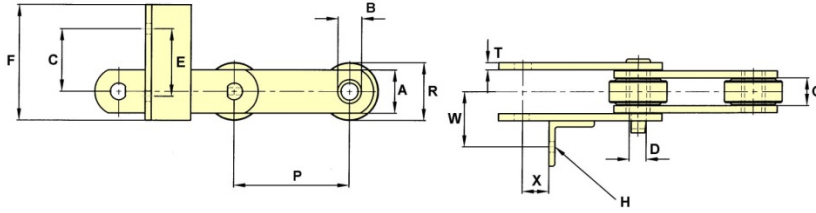

CHAIN NO.	PITCH P	ALLOW. LOAD	U.T.S.	PIN DIA. D	ROLLER DIA. R	SIDEBAR DEPTH A	MAX. GEARING G	BUSH DIA. B	C	E	F	BOLT DIA. H	T	W	X
B5278	6.000	7,650	77,000	0.94	3.50	2.50	1.56	1.25	3.25	3.50	6.00	12MM	0.38	2.87	1.38
09063	6.000	8,300	140,000	0.94	3.00	2.38	1.50	1.25	3.25	3.50	6.00	0.50	0.41	2.87	1.23

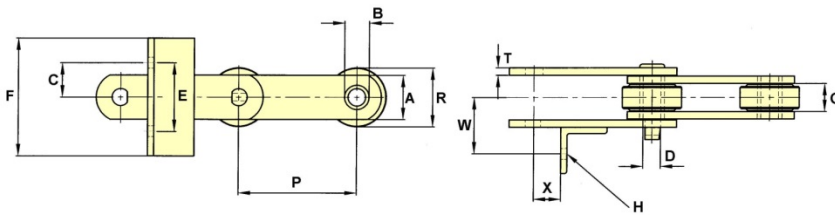

CHAIN NO.	PITCH P	ALLOW. LOAD	U.T.S.	PIN DIA. D	ROLLER DIA. R	SIDEBAR DEPTH A	MAX. GEARING G	BUSH DIA. B	C	E	F	BOLT DIA. H	T	W	X
B5278	6.000	7,650	77,000	0.94	3.50	2.50	1.56	1.25	1.75	3.500	5.00	12MM	0.38	3.65	3.00

Lug Only Attachments

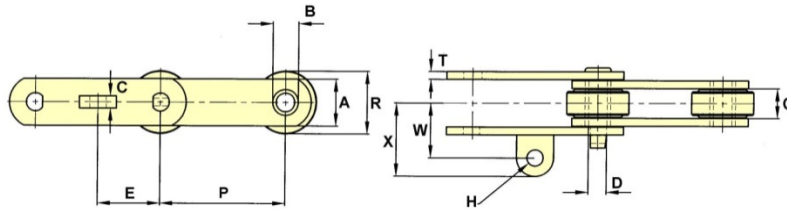

CHAIN NO.	PITCH P	ALLOW. LOAD	U.T.S.	PIN DIA. D	ROLLER DIA. R	SIDEBAR DEPTH A	MAX. GEARING G	BUSH DIA. B	C	E	BOLT DIA. H	T	W	X
B5262	6.000	6,600	100,000	0.75	2.75	2.00	1.56	1.13	15MM	3.00	0.63	0.38	2.75	3.73
B5273	6.000	7,650	70,500	0.88	2.75	60MM	1.51	1.38	30MM	3.00	0.75	10MM	2.89	3.83
B5294	6.000	5,740	49,000	0.75	2.75	2.00	1.69	1.13	12MM	3.00	18MM	0.25	3.53	4.39

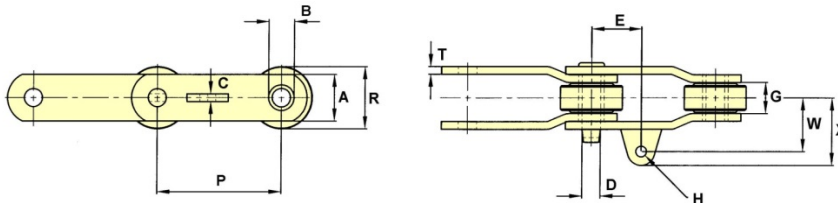

CHAIN NO.	PITCH P	ALLOW. LOAD	U.T.S.	PIN DIA. D	ROLLER DIA. R	SIDEBAR DEPTH A	MAX. GEARING G	BUSH DIA. B	C	E	BOLT DIA. H	T	W	X
B5515	9.000	8,500	120,000	1.00	3.50	2.25	1.50	1.50	15MM	4.50	0.75	0.38	3.12	4.12

* The tabular dimensions and weights are approximate and are not binding. Design improvements may result in variation from the published figures and verification is recommended.



Juice Strainer (Cush-Cush) Chains

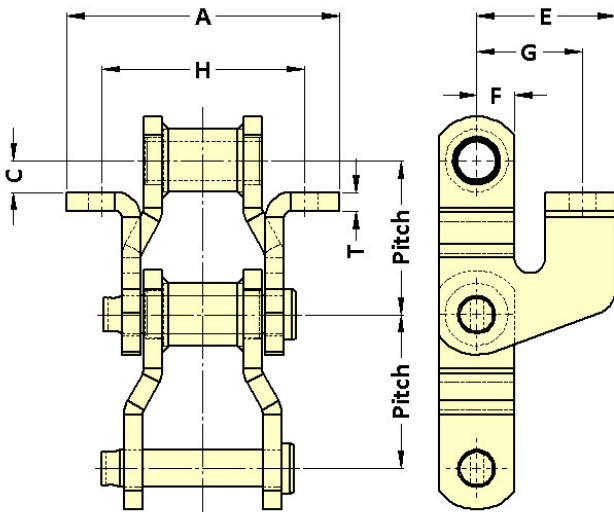
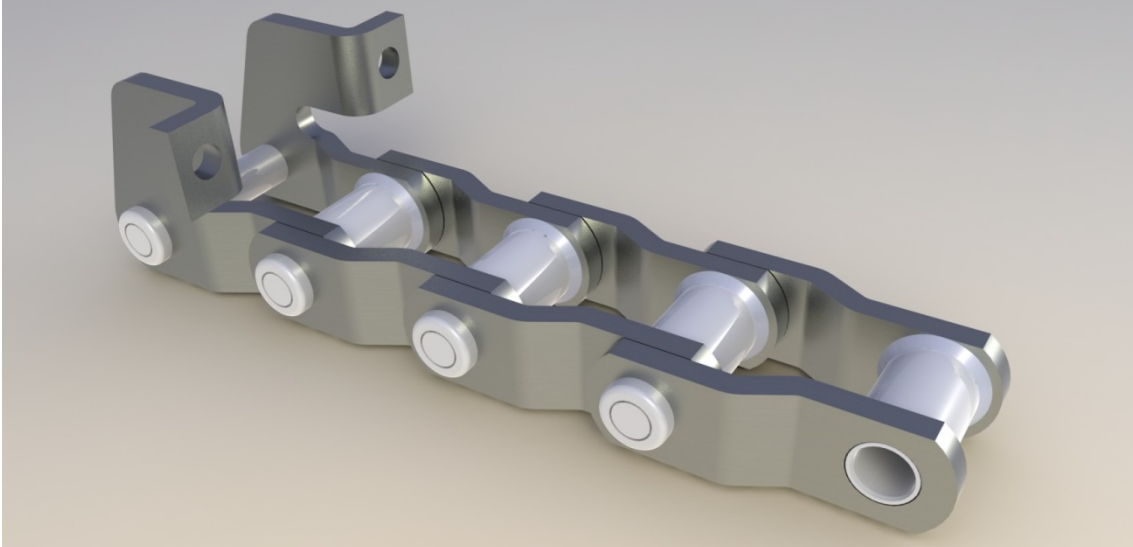

E2103

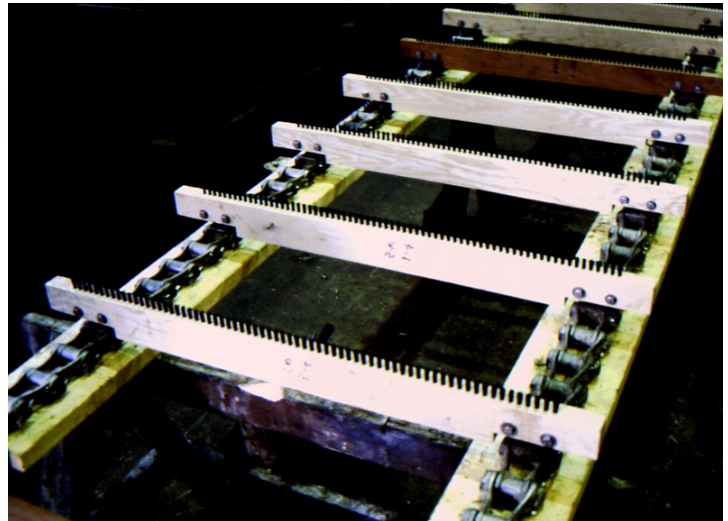

Chain	Pitch	Allowable Chain Pull	Breaking Load		Weight / Ft		Pin		Barrel			Link Depth	A	B	C	D	E	F	G	H	T
			Lb	KG	Plain	F2/29	Dia	Length	Dia	Width Inside	Width Outside										
488	2.61	1,800	11,000	4,994	3.5	6.2	.44	3.06	.88	.75	1.56	1.0	2.94	.88	1.56	.31	2.0	.5	1.38	2.03	.31
4103	3.07	3,500	22,000	9,988	6.2	8.8	.75	3.63	1.25	1.0	1.84	1.5	3.0	-	.44	.38	2.63	.75	2.02	2.44	.44
2103	3.07	4,900	34,000	13,140	5.9	9.3	.75	3.13	1.25	1.38	1.88	1.5	4.88	-	.63	.38	2.75	.75	2.09	3.5	.25

4103 available in stainless

* The tabular dimensions and weights are approximate and are not binding. Design improvements may result in variation from the published figures and verification is recommended.



Trash Conveyor Chains

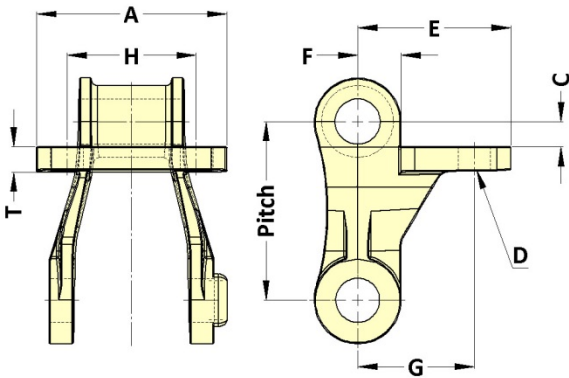
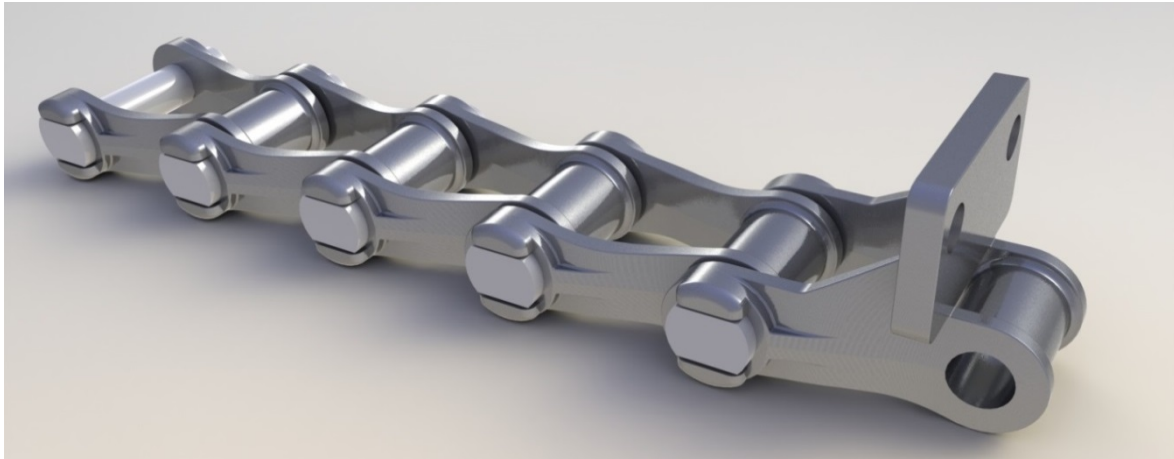

4103 F29

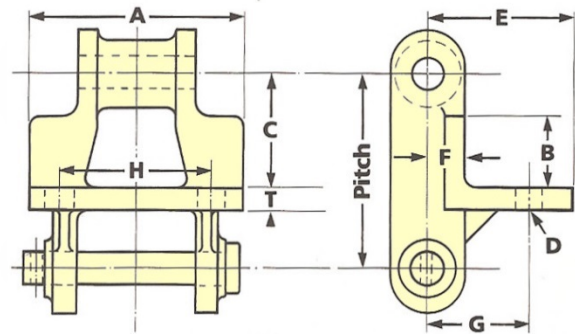

488



Pintle chains for use primarily in juice strainer and trash elevator applications. Where the application requires resistance to severe corrosion STAINLESS STEEL versions can be selected.



Slats, Sprockets and Buckets

REMEMBER

When seeking accessories advise the chain number they are to work with. The following information supplied with enquiry or order will avoid delay and ensure supplies are to your requirements.

Slats

Style, length and thickness, if required pre-punched advise chain centres.

Sprockets

Number of teeth and bore detail, because wheels are made to order and boss made to suit we need to know the final bore even if wheels are to be supplied un-machined. Unless instructed otherwise central bosses and rectangular taper keyways will be standard.

Buckets

Type i.e. pressed, fabricated or plastic. Size : A Length, B Breadth, C Centre depth and D Projection and thickness of material.

Slats

Our top quality mild steel slats are available for our Main, Auxiliary and intermediate carrier chains. Pressed steel channels with or without central corrugation are available for bagasse conveyors.

Manufactured using a multi pressure progressive forming process for controlled linear and profile accuracy, jig punched holes for consistent results all ensure a top quality product

For Cane Carriers

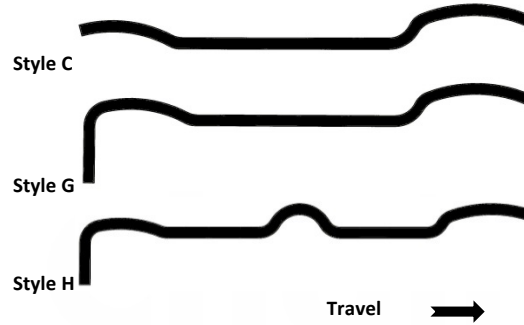

For Intermediate Carriers

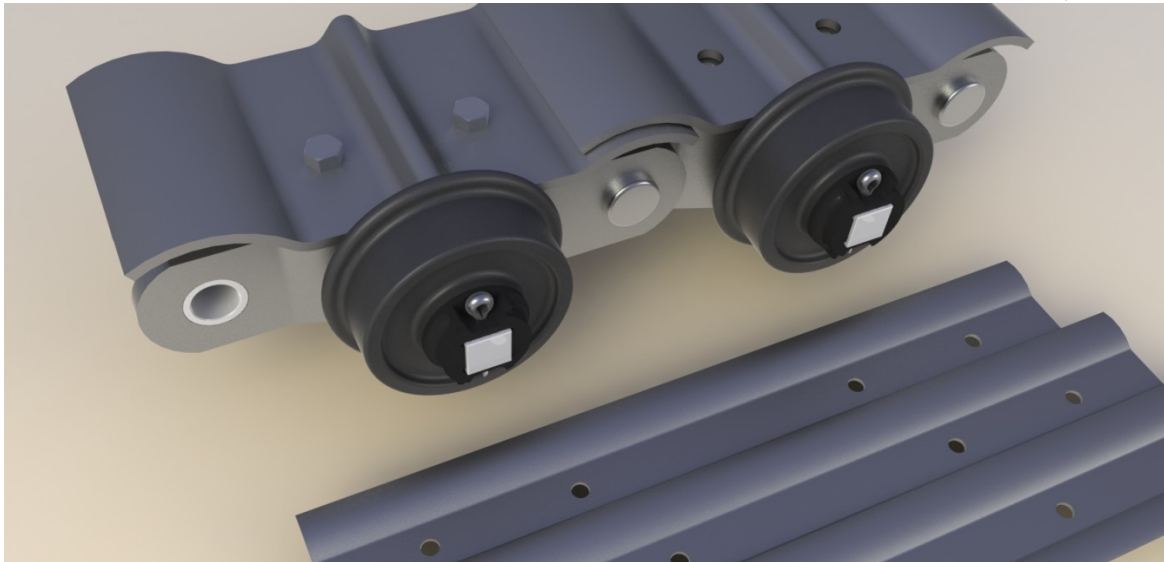
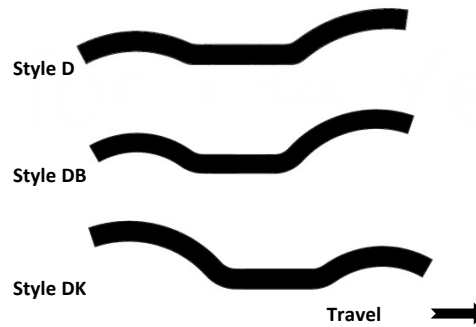



Sprockets

All Ewart's Sugar chain wheels are now manufactured from carbon steel plate EN8 (equates to the analysis of SAE1040). Very accurate profiles are assured by magic eye guided flame cutters. Mild steel bosses are made to suit shaft size used to avoid unnecessary weight, and are argon arc welded both sides to full depth plate to complete the fabrication. The assembly is then furnace normalised to remove stresses set up in manufacture. Teeth sides above the PCD are chamfered to ensure easy entry between sidebars. After this process, the teeth surfaces can be flame hardened to resist wear in very arduous conditions but in roller chain applications we find this is rarely required.

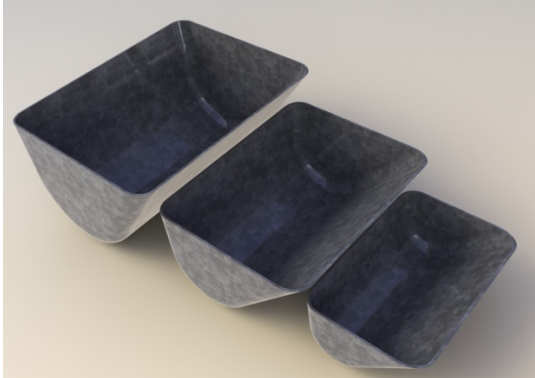

Buckets for Sugar Elevators

A full range of pressed and fabricated steel, plastic and cast nylon buckets are available in a variety of finishes to meet most needs.

How to measure buckets

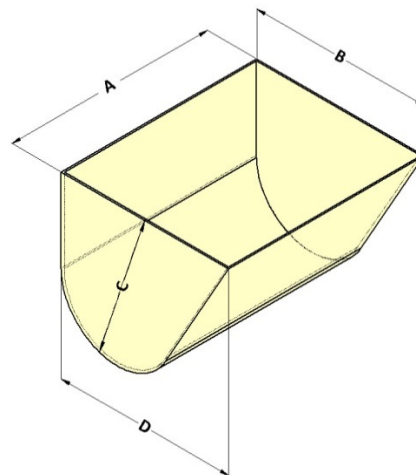



Sugar Elevator Chains

Many of Ewarts standard products can be used in sugar elevators, a small cross section is shown here.

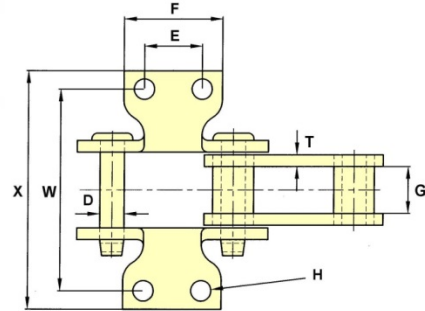
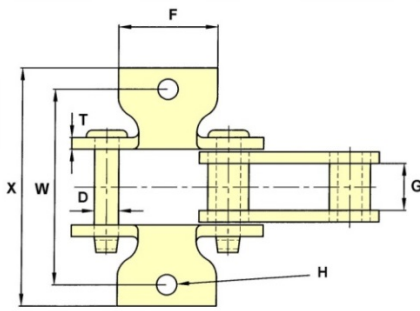
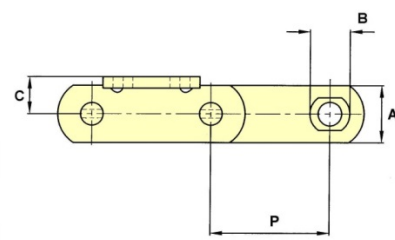
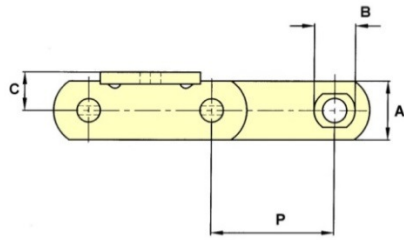
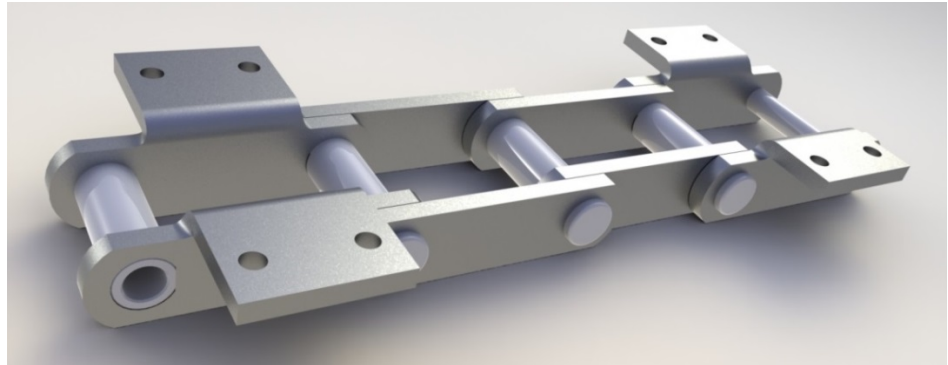

K1

K2

K1 Attachments

CHAIN NO.	PITCH P	ALLOW. LOAD	U.T.S.	PIN DIA. D	SIDEBAR DEPTH A	MAX GEARING G	BARREL DIA. B	C	F	BOLT DIA. H	T	W	X
SS188	2.609	2,800	25,000	0.50	1.25	1.06	0.87	0.81	2.13	0.38	0.25	3.75	2.61

K2 Attachments

CHAIN NO.	PITCH P	ALLOW. LOAD	U.T.S.	PIN DIA. D	SIDEBAR DEPTH A	MAX GEARING G	BARREL DIA. B	C	E	F	BOLT DIA. H	T	W	X
SS188	2.609	2,800	25,000	0.50	1.25	1.06	0.88	0.81	1.25	2.13	0.38	0.25	4.19	5.13
SS131	3.075	4,500	40,000	0.62	1.50	1.31	1.25	1.00	1.50	2.63	0.50	0.38	4.13	5.13
SS102B	4.000	6,300	40,000	0.62	1.50	2.13	1.00	1.00	1.75	2.69	0.38	0.38	5.31	6.66
SS111	4.750	8,850	75,000	0.75	2.00	2.63	1.44	1.50	2.31	3.63	0.38	0.38	6.25	8.06
SS110	6.000	6,300	40,000	0.62	1.50	2.13	1.25	1.00	1.75	2.88	0.38	0.38	5.31	6.66
BS239	6.000	8,860	75,000	0.75	2.00	2.62	1.44	1.50	2.31	4.50	0.50	0.38	6.25	8.38

SS102B CAN BE SUPPLIED WITH 1.1/2" DIA. ROLLERS IF REQUIRED

* The tabular dimensions and weights are approximate and are not binding. Design improvements may result in variation from the published figures and verification is recommended.



Sugar Elevator Chains

Steel Bushed Chain

K2 Attachments

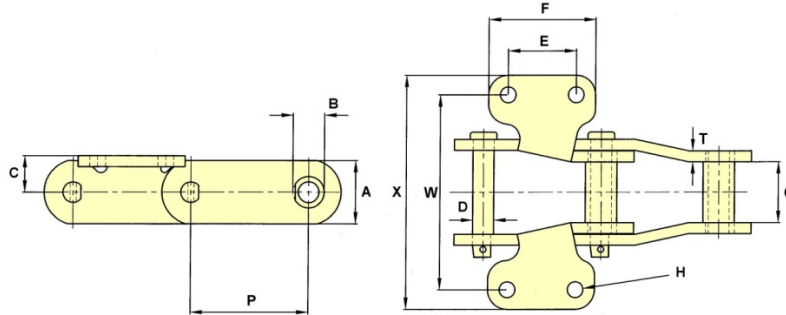

CHAIN NO.	PITCH P	ALLOW. LOAD	U.T.S.	PIN DIA. D	SIDEBAR DEPTH A	MAX GEARING G	BARREL DIA. B	C	E	F	BOLT DIA. H	T	W	X
7140X	6.060	15,800	70,000	1.06	3.25	3.13	1.63	1.88	3.50	5.50	0.62	0.56	10.00	12.00

A1 Attachment

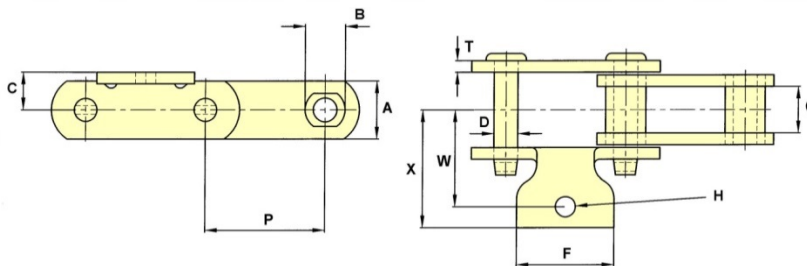

CHAIN NO.	PITCH P	ALLOW. LOAD	U.T.S.	PIN DIA. D	SIDEBAR DEPTH A	MAX GEARING G	BARREL DIA. B	C	F	BOLT DIA. H	T	W	X
SS188	2.609	2,800	25,000	0.50	1.25	1.06	0.87	0.81	2.13	0.38	0.25	1.87	1.56

AS20 Attachment

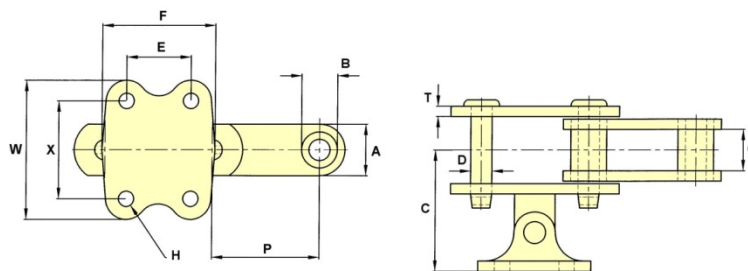

CHAIN NO.	PITCH P	ALLOW. LOAD	U.T.S.	PIN DIA. D	SIDEBAR DEPTH A	MAX GEARING G	BARREL DIA. B	C	E	F	BOLT DIA. H	W	X
SS188	2.609	2,800	25,000	0.50	1.25	1.06	0.88	2.94	1.56	2.75	0.31	3.19	2.19
SS102B	4.000	6,300	40,000	0.62	1.50	2.13	1.00	3.89	1.69	3.13	0.31	3.50	2.44
SS110	6.000	6,300	40,000	0.62	1.50	2.13	1.25	4.25	2.50	4.00	0.38	3.50	2.25
B5239	6.000	8,860	75,000	0.75	2.00	2.62	1.44	4.69	2.50	3.75	0.50	4.25	3.00

* The tabular dimensions and weights are approximate and are not binding. Design improvements may result in variation from the published figures and verification is recommended.



Sugar Elevator Chains

Steel Bushed Chain

G20 Attachment

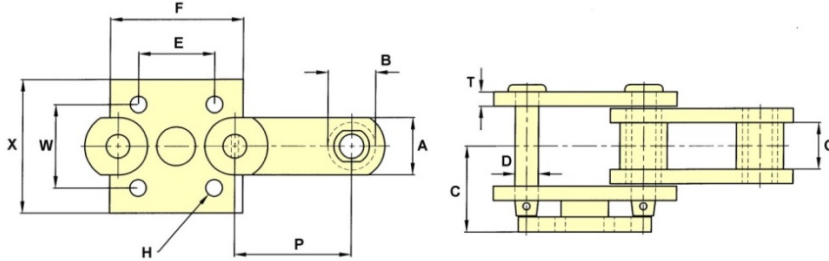

CHAIN NO.	PITCH P	ALLOW. LOAD	U.T.S.	PIN DIA. D	SIDEBAR DEPTH A	MAX. GEARING G	BUSH DIA. B	C	E	F	BOLT DIA. H	W	X
SS131	3.075	4,500	40,000	0.62	1.50	1.31	1.25	2.25	2.00	3.50	0.38	2.19	3.50

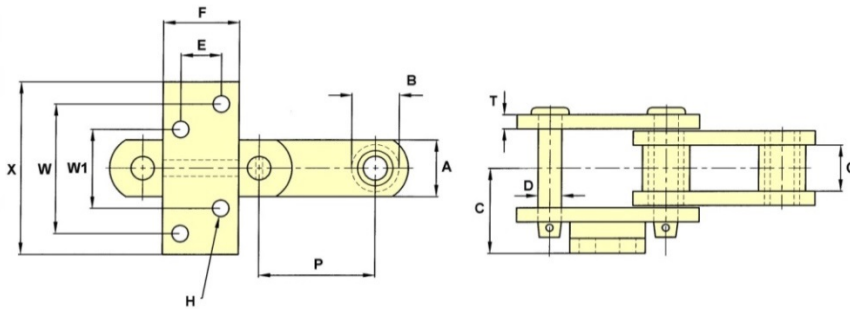

CHAIN NO.	PITCH P	ALLOW. LOAD	U.T.S.	PIN DIA. D	SIDEBAR DEPTH A	MAX. GEARING G	BUSH DIA. B	C	E	F	BOLT DIA. H	W	W1	X
SS103	3.075	4,100	25,000	0.62	1.50	1.90	1.22	2.06	0.63	2.00	0.38	3.00	1.75	4.00

* The tabular dimensions and weights are approximate and are not binding. Design improvements may result in variation from the published figures and verification is recommended.



Sugar Elevator Chains

Steel Roller Chain

A2 Attachment

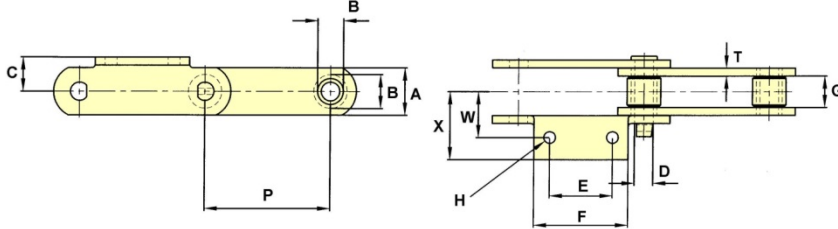

CHAIN NO.	PITCH P	ALLOW. LOAD	U.T.S.	PIN DIA. D	ROLLER DIA. R	SIDEBAR DEPTH A	MAX. GEARING G	BUSH DIA. B	C	E	F	BOLT DIA. H	T	W	X
0904E	4.000	4,850	40,000	0.69	1.25	1.75	1.22	1.00	1.25	1.44	2.63	0.38	0.31	1.75	2.06

AS20 Attachment

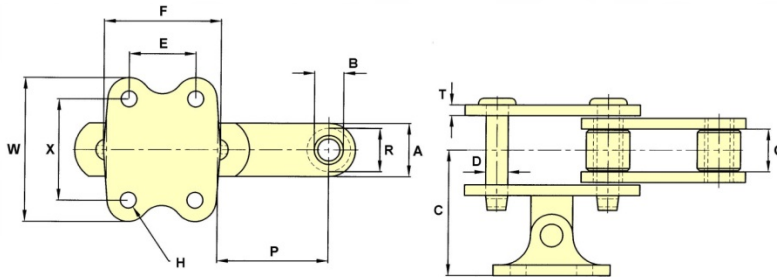

CHAIN NO.	PITCH P	ALLOW. LOAD	U.T.S.	PIN DIA. D	ROLLER DIA. R	SIDEBAR DEPTH A	MAX. GEARING G	BUSH DIA. B	C	E	F	BOLT DIA. H	T	W	X
0904E	4.000	4,850	40,000	0.69	1.25	1.75	1.22	1.00	3.13	2.00	3.63	0.38	0.31	3.56	2.19
09060E	6.000	6,350	60,000	0.75	1.63	2.00	1.50	1.13	4.13	2.50	3.75	0.50	0.38	4.25	3.00
1796E	6.000	7,500	100,000	0.87	1.63	2.25	1.50	1.25	4.13	2.50	3.75	0.50	0.38	4.25	3.00

G2 Attachment

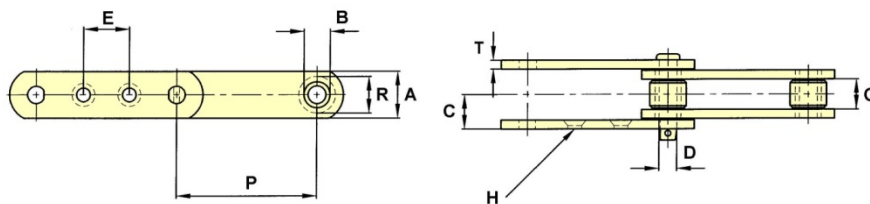

CHAIN NO.	PITCH P	ALLOW. LOAD	U.T.S.	PIN DIA. D	ROLLER DIA. R	SIDEBAR DEPTH A	MAX. GEARING G	BUSH DIA. B	C	E	BOLT DIA. H	T
3008	150MM	1,860	28,000	0.44	0.87	35MM	21MM	0.65	0.82	60MM	10MM	5MM
MXS2842	6.048	6,600	40,000	0.69	1.38	1.75	2.13	1.08	1.7	2.50	0.50	0.31

MXS2842 is a cranked link design.

* The tabular dimensions and weights are approximate and are not binding. Design improvements may result in variation from the published figures and verification is recommended.



Sugar Elevator Chains

Steel Roller Chain

G4 Attachment

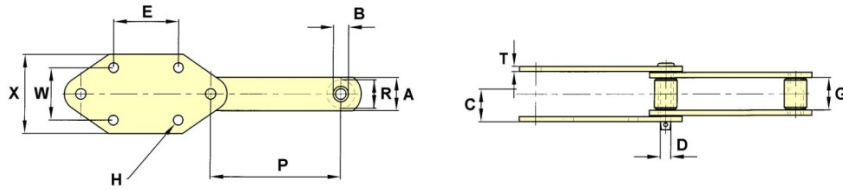

CHAIN NO.	PITCH P	ALLOW. LOAD	U.T.S.	PIN DIA. D	ROLLER DIA. R	SIDEBAR DEPTH A	MAX. GEARING G	BUSH DIA. B	C	E	BOLT DIA. H	T	W	X
B5440	200MM	4,500	45,000	0.62	1.38	1.75	2.09	0.94	1.85	3.94	15MM	0.31	3.94	5.75
B5440	200MM	4,500	45,000	0.62	1.38	1.75	2.09	0.94	1.36	3.94	15MM	0.31	3.15	4.75

K2 Attachment

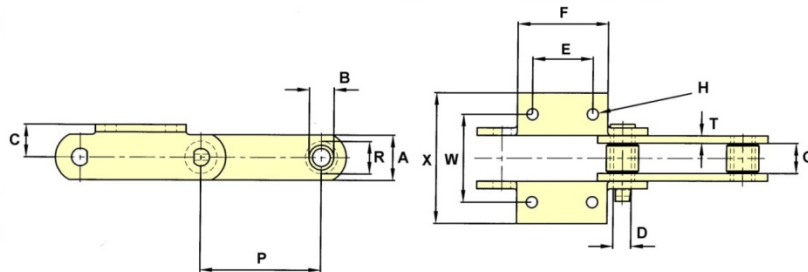

CHAIN NO.	PITCH P	ALLOW. LOAD	U.T.S.	PIN DIA. D	ROLLER DIA. R	SIDEBAR DEPTH A	MAX. GEARING G	BUSH DIA. B	C	E	F	BOLT DIA. H	T	W	X
0904E	4.000	4,850	40,000	0.69	1.25	1.75	1.22	1.00	1.25	1.44	2.63	0.38	0.31	3.50	4.13
09060E	6.000	6,350	60,000	0.75	1.63	2.00	1.50	1.13	1.63	3.00	4.50	0.50	0.38	4.38	6.75
1796E	6.000	7,500	100,000	0.87	1.63	2.25	1.50	1.25	1.63	3.00	4.50	0.50	0.38	4.38	6.50

* The tabular dimensions and weights are approximate and are not binding. Design improvements may result in variation from the published figures and verification is recommended.



Sugar Elevator Chains

Combination Chain

A1 Attachment

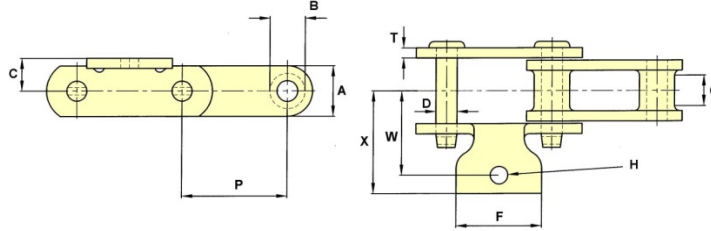

CHAIN NO.	PITCH P	ALLOW. LOAD	U.T.S.	PIN DIA. D	SIDEBAR DEPTH A	MAX GEARING G	BARREL DIA. B	C	F	BOLT DIA. H	T	W	X
C188	2.609	2,000	17,500	0.50	1.25	0.75	0.87	0.81	2.13	0.38	0.25	1.88	2.56

ATTACHMENTS ARE ONLY AVAILABLE ON THE OUTER LINK

A2 Attachment

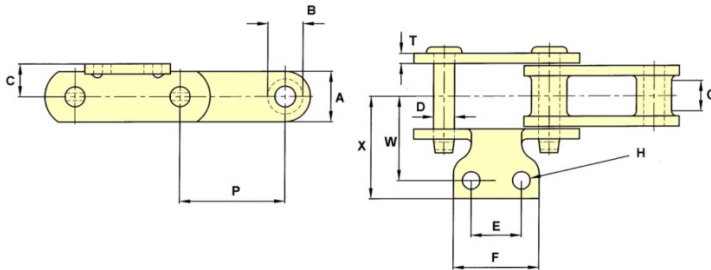

CHAIN NO.	PITCH P	ALLOW. LOAD	U.T.S.	PIN DIA. D	SIDEBAR DEPTH A	MAX GEARING G	BARREL DIA. B	C	E	F	BOLT DIA. H	T	W	X
C188	2.609	2,000	17,500	0.50	1.25	0.75	0.87	0.81	1.25	2.13	0.38	0.25	2.09	2.56
C131	3.075	3,220	27,500	0.62	1.50	1.13	1.25	1.00	1.50	2.63	0.50	0.38	2.06	2.63
C102B	4.000	4,200	27,500	0.62	1.50	1.75	1.00	1.00	1.75	2.69	0.38	0.38	2.66	3.33

ATTACHMENTS ARE ONLY AVAILABLE ON THE OUTER LINK

AS20 Attachment

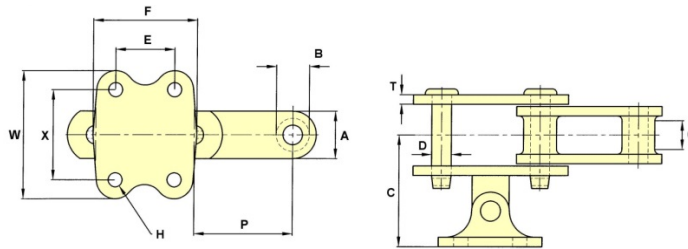

CHAIN NO.	PITCH P	ALLOW. LOAD	U.T.S.	PIN DIA. D	SIDEBAR DEPTH A	MAX GEARING G	BARREL DIA. B	C	E	F	BOLT DIA. H	W	X
C188	2.609	2,000	17,500	0.50	1.25	0.75	0.87	2.94	1.56	2.75	0.31	3.19	2.19
C131	3.075	3,220	27,500	0.62	1.50	1.13	1.25	3.47	1.69	3.13	0.31	3.50	2.44
C102B	4.000	4,200	27,500	0.62	1.50	1.75	1.00	3.89	1.69	3.13	0.31	3.50	2.44
C111	4.760	6,000	36,000	0.75	1.75	2.25	1.44	4.72	2.50	3.75	0.50	4.25	3.00
C110	6.000	4,200	27,500	0.62	1.50	1.75	1.25	4.25	2.50	4.00	0.38	3.50	2.25

ATTACHMENTS ARE ONLY AVAILABLE ON THE OUTER LINK

* The tabular dimensions and weights are approximate and are not binding. Design improvements may result in variation from the published figures and verification is recommended.



Sugar Elevator Chains

Combination Chain

G4 Attachment

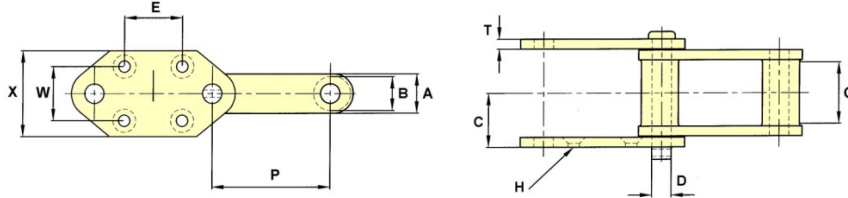

CHAIN NO.	PITCH P	ALLOW. LOAD	U.T.S.	PIN DIA. D	SIDEBAR DEPTH A	MAX GEARING G	BARREL DIA. B	C	E	BOLT DIA. H	T	W	X
C132	6.050	10,000	60,000	1.00	2.00	2.88	1.72	2.72	75MM	15MM	0.50	70MM	4.38

K1 Attachment

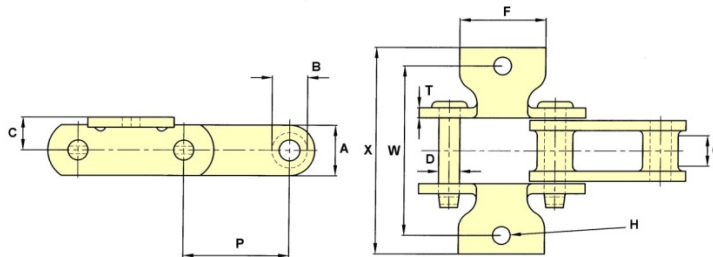

CHAIN NO.	PITCH P	ALLOW. LOAD	U.T.S.	PIN DIA. D	SIDEBAR DEPTH A	MAX GEARING G	BARREL DIA. B	C	F	BOLT DIA. H	T	W	X
C188	2.609	2,000	17,500	0.50	1.25	0.75	0.87	0.81	2.13	0.38	0.25	3.75	5.13

ATTACHMENTS ARE ONLY AVAILABLE ON THE OUTER LINK

K2 Attachment

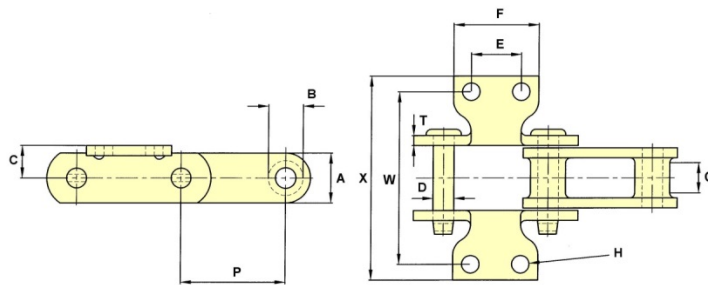

CHAIN NO.	PITCH P	ALLOW. LOAD	U.T.S.	PIN DIA. D	SIDEBAR DEPTH A	MAX GEARING G	BARREL DIA. B	C	E	F	BOLT DIA. H	T	W	X
C188	2.609	2,000	17,500	0.50	1.25	0.75	0.87	0.81	1.25	2.13	0.38	0.25	4.19	5.13
C131	3.075	3,220	27,500	0.62	1.50	1.13	1.25	1.00	1.50	2.63	0.50	0.38	4.13	5.25
C102B #	4.000	4,200	27,500	0.62	1.50	1.75	1.00	1.00	1.75	2.69	0.38	0.38	5.31	6.66
C111	4.760	6,000	36,000	0.75	1.75	2.25	1.44	1.13	2.31	3.63	0.38	0.38	6.25	7.50
C110	6.000	4,200	27,500	0.62	1.50	1.75	1.25	1.00	1.75	2.87	0.38	0.38	5.31	6.69
C132	6.050	10,000	60,000	1.00	2.00	2.88	1.72	1.25	2.75	4.00	0.50	0.50	7.50	9.18

K2 ATTACHMENTS FOR CENTRE LINK ARE ONLY AVAILABLE ON C102B

* The tabular dimensions and weights are approximate and are not binding. Design improvements may result in variation from the published figures and verification is recommended.



Sugar Elevator Chains

Cast Chain

Grey Pin Chains

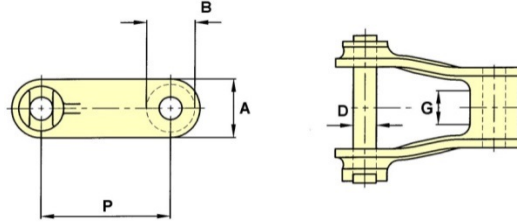

CHAIN NO.	PITCH P	ALLOW. LOAD	U.T.S.	PIN DIA. D	SIDEBAR DEPTH A	MAX GEARING G	BARREL DIA. B
503	3.020	2,810	20,000	0.56	1.38	1.13	1.09
504	4.060	4,500	27,500	0.63	1.69	1.75	1.31
578	2.630	1,780	15,000	0.44	1.19	0.88	0.97

AS20 Attachment

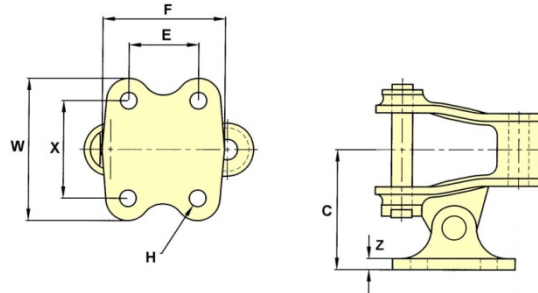

CHAIN NO.	C	E	F	BOLT DIA. H	W	X	Z
503	2.88	1.69	3.13	0.31	3.5	2.44	0.28
504	3.81	2.50	4.13	0.38	3.69	2.25	0.44
578	2.69	1.56	2.75	0.31	3.19	2.19	0.25

G20 & G22 Attachment

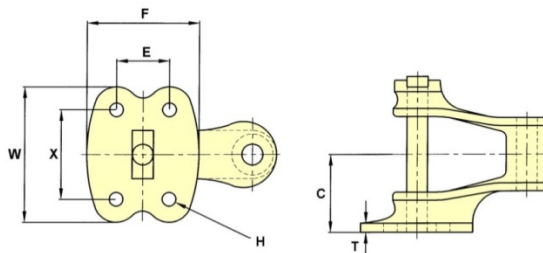

CHAIN NO.	C	E	F	BOLT DIA. H	T	W	X
503G20	2.13	1.69	3.06	0.31	0.25	3.44	2.44
504G20	2.75	1.88	3.50	0.38	0.31	3.63	2.50
578G22	2.19	1.56	3.00	0.31	0.22	3.50	2.19

* The tabular dimensions and weights are approximate and are not binding. Design improvements may result in variation from the published figures and verification is recommended.



Sugar Elevator Chains

Cast Chain

Grey Pin Chains

K1 Attachment

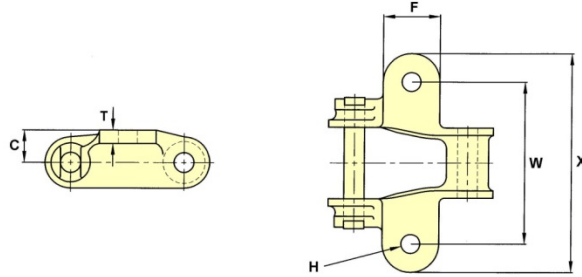

CHAIN NO.	C	F	BOLT DIA. H	T	W	X
503	0.88	1.63	0.38	0.31	4.38	5.63
578	0.75	1.31	0.38	0.31	3.81	5.13

K2 Attachment

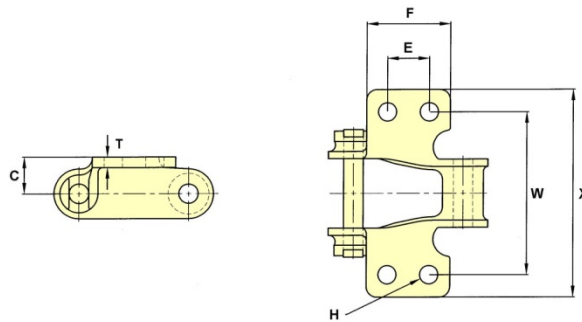

CHAIN NO.	C	E	F	BOLT DIA. H	T	W	X
578	0.88	1.00	2.06	0.38	0.25	3.88	5.00
503	0.88	1.81	2.94	0.38	0.28	5.38	6.88
504	1.00	1.50	2.63	0.50	0.50	5.81	7.00

* The tabular dimensions and weights are approximate and are not binding. Design improvements may result in variation from the published figures and verification is recommended.



Sugar Elevator Chains

Cast Chains

Ley Bush Chains

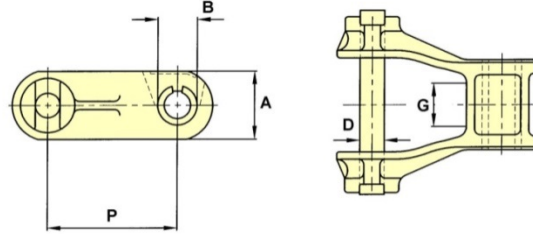

CHAIN NO.	PITCH P	ALLOW. LOAD	U.T.S.	PIN DIA. D	SIDEBAR DEPTH A	MAX GEARING G	BARREL DIA. B
603	3.000	3,300	20,000	0.56	1.56	1.13	0.88

AS20 Attachment

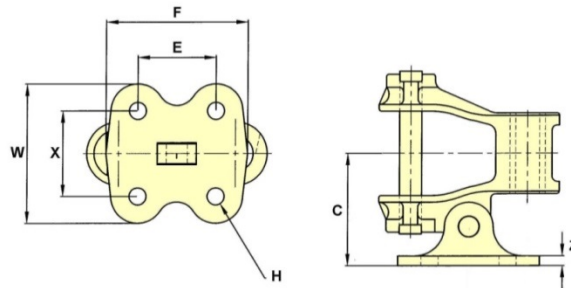

CHAIN NO.	C	E	F	BOLT DIA. H	W	X	Z
603	2.81	2.00	3.63	0.38	3.56	2.13	0.25

G20 Attachment

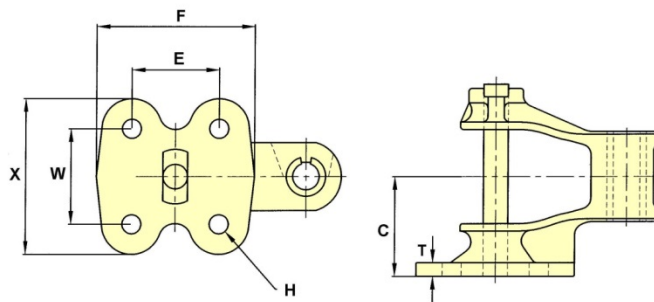

CHAIN NO.	C	E	F	BOLT DIA. H	T	W	X
603G20	2.25	2.00	3.63	0.38	0.31	2.19	3.44

* The tabular dimensions and weights are approximate and are not binding. Design improvements may result in variation from the published figures and verification is recommended.



Sugar Elevator Chains

Cast Chains

Ley Bush Chains

K1 Attachment

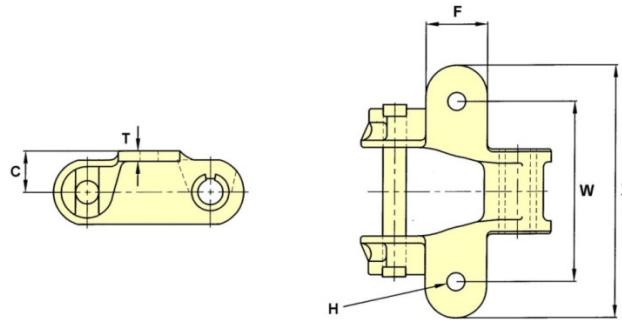

CHAIN NO.	C	F	BOLT DIA. H	T	W	X
603	1.00	1.50	0.38	0.25	4.38	6.13

K2 Attachment

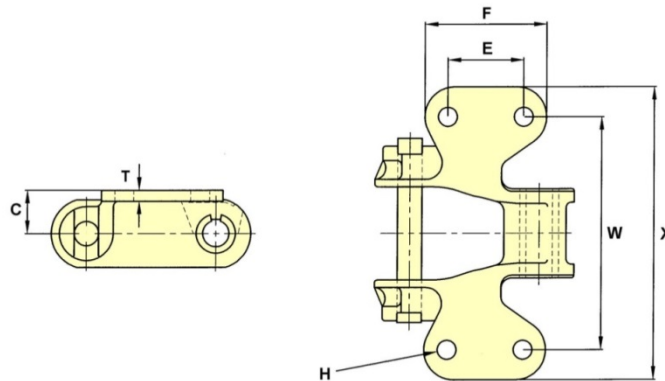

CHAIN NO.	C	E	F	BOLT DIA. H	T	W	X
603	1.00	1.75	2.81	0.38	0.25	5.38	6.88

* The tabular dimensions and weights are approximate and are not binding. Design improvements may result in variation from the published figures and verification is recommended.



Boiler Chains

Boiler Feed

Steel Chain

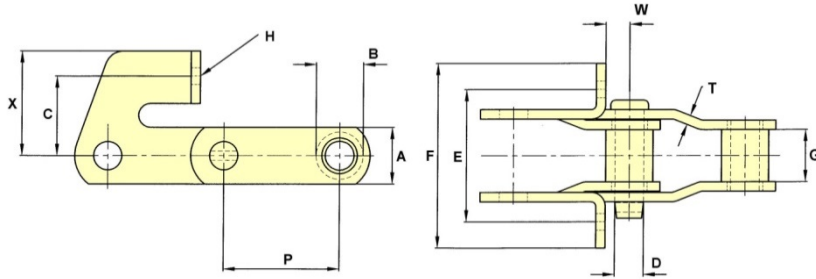

CHAIN NO.	PITCH P	ALLOW. LOAD	U.T.S.	PIN DIA. D	SIDEBAR DEPTH A	MAX. GEARING G	BUSH DIA. B	C	E	F	BOLT DIA. H	T	W	X
E2103	3.075	4,900	34,000	0.75	1.50	1.38	1.25	2.09	3.50	4.88	0.38	0.25	0.63	2.75

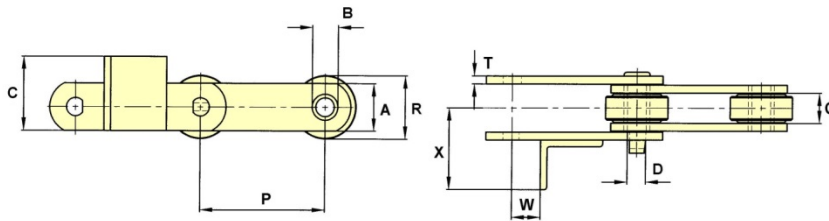

CHAIN NO.	PITCH P	ALLOW. LOAD	U.T.S.	PIN DIA. D	ROLLER DIA. R	SIDEBAR DEPTH A	MAX. GEARING G	BUSH DIA. B	C	T	W	X
B5051	3.000	2,000	6,000	0.51	1.13	25MM	0.69	0.79	1.50	4MM	0.61	2.44

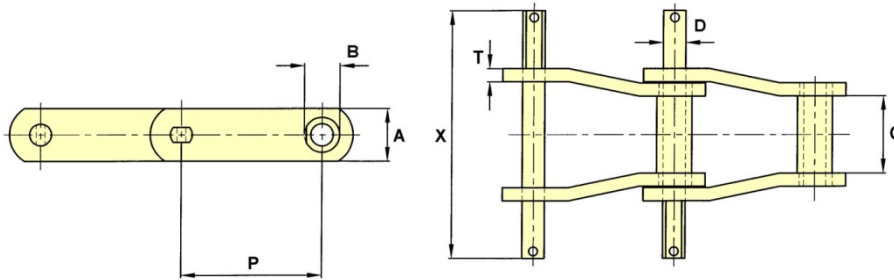

CHAIN NO.	PITCH P	ALLOW. LOAD	U.T.S.	PIN DIA. D	SIDEBAR DEPTH A	MAX. GEARING G	BUSH DIA. B	T	X
B5063	4.000	6,300	50,000	0.62	1.50	2.13	1.00	0.38	7.06
B5109	4.000	6,400	67,000	0.62	1.50	2.19	1.00	0.38	7.03

* The tabular dimensions and weights are approximate and are not binding. Design improvements may result in variation from the published figures and verification is recommended.



Boiler Chains

Boiler Feed

Steel Chain

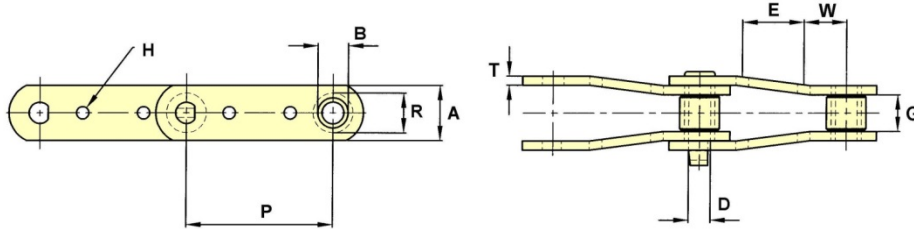

CHAIN NO.	PITCH P	ALLOW. LOAD	U.T.S.	PIN DIA. D	ROLLER DIA. R	SIDEBAR DEPTH A	MAX. GEARING G	BUSH DIA. B	E	H	T	W
B5309	6.000	7,100	45,000	0.69	36MM	1.75	2.13	1.00	2.50	12MM	0.31	1.75
MXS2842	6.048	6,600	40,000	0.69	1.38	1.75	2.13	1.08	2.50	0.52	0.31	1.78

Cast Pintle Chain

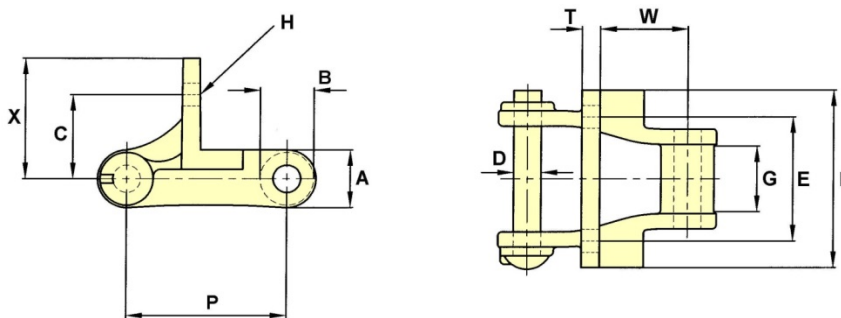

CHAIN NO.	PITCH P	ALLOW. LOAD	U.T.S.	PIN DIA. D	B	C	E	F	BOLT DIA. H	T	W	X
488F2	2.609	1,800	11,000	0.44	0.87	1.38	2.03	2.91	0.31	0.28	1.42	1.97

* The tabular dimensions and weights are approximate and are not binding. Design improvements may result in variation from the published figures and verification is recommended.



General Installation & Maintenance Instructions

Chain and Sprocket Wheels

Direction of Chain Travel on Conveyors and Elevators

Non-Roller Cranked Sided Chain

For minimum wear of the chain and sprocket wheel teeth, it is important when fitting the chain to ensure that the open end or tail end of the links are leading (fig.1)

As the links engage the main sprocket, where the pull of the chain is greater than of any other point, the barrel of each link settles on a tooth in the position it will occupy during its passage until disengagement from the sprocket (fig.2). At this point, limited rotation of the link barrel occurs during articulation but it does so under a lower chain pull than at the moment of entry. If the chain is arranged to run in the opposite direction, ie. With the open or tail end following this relative movement of links with respect to the sprocket would take place under maximum chain pull and result in unnecessary wear. Therefore the chain should travel tail first as illustrated in fig.1.

The foregoing applies to all crank-sided non-roller chains with the exception of Chain of the Intermediate carrier type illustrated in fig.3. With this type of chain, double sprockets engage with the integral driving bosses at each side of the open or tail end of the link and, to obtain maximum life, this chain should travel head first as indicated.

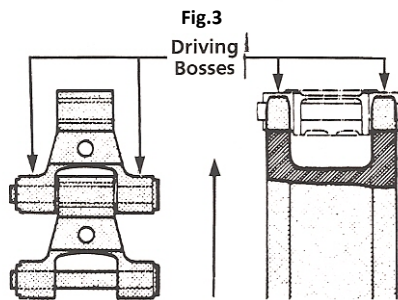
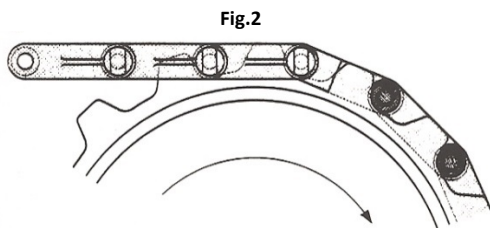
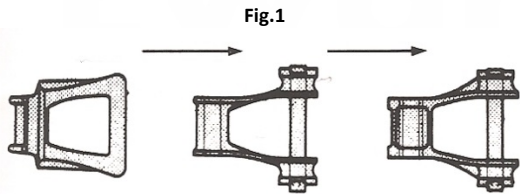

Non-Roller Straight Sided Chain

Non-roller straight sided chains including Combination chains may obviously travel in either direction (fig.4).

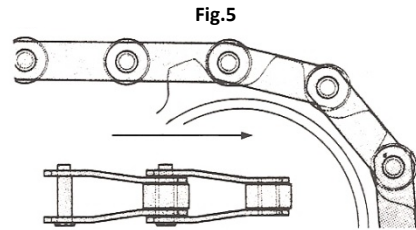
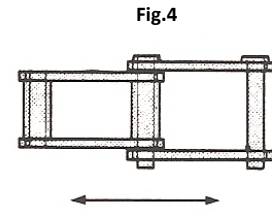

Roller Chain

For minimum wear, it is important that this type of chain having cranked side bars should travel with the head of the links leading – refer to fig.5. In the case of chains having straight or parallel side bars, the direction of travel is, of course, immaterial.

Matched Chains

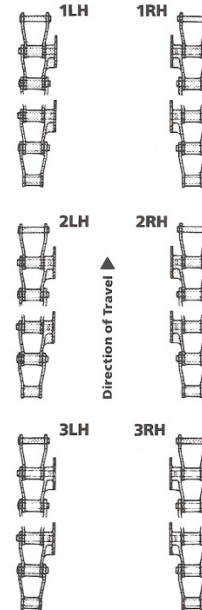

Malleable Cast Chains

Where an elevator or conveyor is fitted with a pair of chains in parallel we 'match' or pair these chains so that every pair of attachment links is in true cross alignment. This prevents any possibility of the links engaging the sprocket wheels carrying unequal loads and so setting up severe racking strains.



It is essential that when assembling such chains each link should be opposite to the link with which it was paired, and to enable this to be done we attach metal labels to each nominal 10ft. coil of chain and these labels carry consecutive numbers.

'Coil No. 1, L.H is coupled to Coil No. 2, L.H' and so on.

'Coil No. 1, R.H is coupled to Coil No. 2, R.H' and so on.

'Coil No. 1, R.H must be assembled exactly opposite to

'Coil No. 1, L.H'. On wheels for 'Matched' or 'Double Strand' chains.

In the case of multi-strand chains a similar procedure would be followed with the 'fitting' symbol notations as applicable.

For double strand chains the pins where applicable are normally fitted with the head on the outside of the conveyor or elevator chain.

Steel Chains

By virtue of precision manufacture, each link in a coil of STEEL chain forms a positive match with its opposite member(s) in a double or multi-strand assemblies, consequently matching labels are not attached to the coils.

STEEL chains only require left and right hand pairing to ensure matching of the chain attachment links.

Drives

Non-Roller Chains

The remarks concerning the direction of travel of elevator and conveyor chains apply also to driving chains when the driving sprocket wheels is smaller than the driven wheel, but with wheels of equal size the chain will travel equally satisfactorily in either direction.

Roller Chains

When the driving sprocket wheel is smaller than the driven wheel, for cranked sidebar chain the narrow end of the link should lead but if the sprockets are of equal diameter the chain may be run in either direction as in straight sided links.

Sprocket Wheels

It is strongly recommended that the teeth of sprocket wheels be regularly inspected for wear since if they continue in service with any appreciable wearing away of the working faces, they will affect the gearing performance causing jerky and irregular running and will rapidly wear out the chain itself. New chain should never be mounted on old wheels unless the teeth of these are in first class condition.

Matched Sprocket Wheels

Sprocket wheels operating with double or multi-strand chains will have been carefully 'matched' with the keyways cut in line so that corresponding teeth are truly parallel in position and it is most important that this 'matching' is correct on installation. A diagram is forwarded showing how these wheel should be assembled on the shafts for 'matching'. Please ensure that your erectors have these instructions before installation.

In the case of idler wheels (i.e. terminal wheels, tail wheels) on double strand or multi-strand elevators or conveyors one wheel should be keyed to its appropriate shaft and the other(s) should run loose between locating collars for each shaft.

This arrangement prevents any possibility of one chain pulling against another through inequalities of pitch, due to stretching. Consequently particular attention should be observed to the free running of the 'loose' wheels.

Chain Tension

The applied tension to the chains should not be greater than the tension merely sufficient to take-up the slack in the chains as EXCESSIVE TENSION CAUSE EXCESSIVE WEAR.

Chain Lubrication

Ewart chains are normally supplied coated with a mineral oil which is intended as a protection against corrosion.

To conserve the life and proper performance of the chain, it is essential that thorough lubrication especially to the bearing surface of the chain is carried out before running and at frequent intervals thereafter.

Sometimes an adequate life and running performance is obtained from chains using little or no lubricant but wherever possible always lubricate. The following notes are intended as a guide for most normal chain applications but Ewart will be pleased to advise of any lubrication problems which fall outside this range.

Choice of Lubricant

The choice of a lubricant is governed by many factors of which the following are most important.

- (A) Physical working conditions
- (B) Ambient temperature

These factors must always be considered when a lubricant is being selected for a specific task.

For Clean Atmosphere and Normal Temperatures

For straightforward applications of clean atmosphere and normal temperatures a Mineral Oil is recommended. The following table indicates the correct grade to apply according to the temperature conditions expected to be encountered.

Temperature		S A E Grade
°C	°F	
Minus 7 to +5	20 to 40	20
5 to 40	40 to 100	30
40 to 60	100 to 140	50

Dirty and Abrasive Atmosphere

Here lubrication presents a problem because loose particles in the atmosphere can be picked up by the lubricant and formed into what is, in effect, a grinding paste.

This problem can be overcome in three ways :-

- (A) By the use of grease which is softened by heating, for application to the chain, but is stiff enough at working temperatures to resist entry of contaminated matter. This application is initially carried out at Ewart by complete immersion of the chain in the grease. Subsequent greasing necessitates complete removal of the old grease before application of the new.
- (B) By the use of normal greases applied internally under pressure which tend to work out any particles from the working surfaces.
- (C) By the use of 'dry' lubrication described below.

Elevated temperatures

Oils may be employed up to a temperature of approximately 150°C. Greases are available which will lubricate satisfactorily up to 260°. Above the latter temperature dry lubrication is virtually essential.



Dry Lubrication

Dry lubrication refers to the use of solid lubricants, generally graphite or molybdenum disulphide. The lubricant is easily applied, by conventional methods, in a colloidal form suspended in a suitable volatile carrier. The carrier evaporates leaving a thin coating of the lubricant on the metal surface. Normally an initial coating would be applied during manufacture, and the user would replenish the film in service by drip feed or spraying. As the carriers are normally low viscosity liquids such as white spirit, application can be effective even when the chain is coated with a stick material, the liquid soaking through the coating, carrying the finely divided lubricant with it.

It will be seen that solid lubricants can be of use in many 'special' applications apart from those already mentioned. Examples are very wet conditions where oil or grease may be removed by washing, or very clean conditions where possible contamination of the product by a fluid lubricant could not be tolerated.

Application Methods

To be effective the lubricant must be delivered to the surfaces where load bearing and movement takes place. Various methods of application can be adopted, the choice being influenced by such factors as type of chain, type of lubricant, arrangement of running gear, surrounding atmosphere, service temperature and speed. The following are methods of lubrication currently employed.

Manual Lubrication

This is the simplest form of lubrication and generally consists of scrubbing the chain with a brush dipped in oil or using an oil can. The method is limited to slow speed drives and where the chain can be stopped for the operation. Chain on open drives or conveyors is often lubricated in this way. Another method for open applications is the an Aerosol Molybdenized chain and drive spray.

Based on a heat-resisting oil, combined with colloidal molybdenum disulphide chain and drive spray is easily applied especially in situations where access is difficult using an ordinary oil can. The aerosol method of application penetrates to the pins and bushes of roller chains, and the powerful lubricating qualities of the additive ensure minimum wear of both chains and sprocket wheels.

The spray and its container have been made so that affine jet can be directed at the chain or machinery being lubricated without contaminating nearby objects. The spray does not collect dirt and fibres and resists water contamination.

Drip Feed Lubrication (Fig.6)

Using a drip cup usually mounted above the lower strand of the chain and arranged to feed into the necessary lubrication areas. This is a semi-automatic method, and is commonly used on low speed open drives or conveyors working in a clean atmosphere.

Fig.6

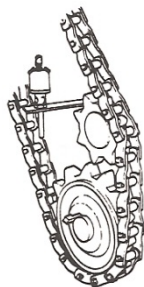

Forced Lubrication (Fig.7)

Entails the lubricant being sprayed on to the chain under pressure. One method for enclosed drives and usually for high speed and heavy load chains, sprays within an oil tight casing and recirculates the oil. Another method for open applications uses fine sprays or jets accurately aimed at the relevant areas.

Fig.7

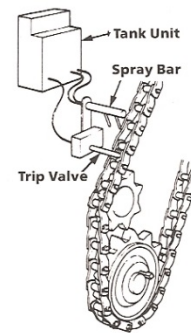

Oil Bath Lubrication (Fig.8)

Applicable to encased drives where the lower portion of the chain case can form a bath for the chain and provides a simple, virtually automatic method of lubrication for all but the highest speeds.

Fig.8

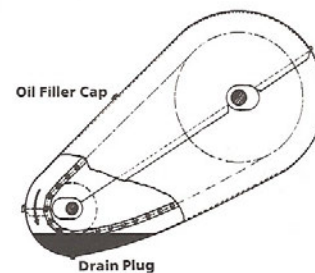

Internal Lubrication (Fig.9)

The lubrication of open drives and conveyor and elevator applications often present s difficulties because of contamination from the surrounding atmosphere. Accelerated wear can result even where the intruding material is not normally considered abrasive.

In suitable cases where physical dimensions permit roller chain can be supplied with fittings and channels suitable for the application of grease under pressure between pin and bush as illustrated. In this case the grease is forced outwards from the bearing areas giving a self cleaning action. The operation may be carried out manually or automatically on medium speed equipment.

Fig.9

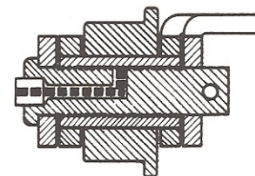

The foregoing information should satisfy requirements for the majority of chain applications, but it is appreciated that there are still cases where efficient lubrication presents some difficulty. In such cases, Ewart will be pleased to offer advice based on their wide experience of chain engineering.



Conveyor Chain Selection Formulas

Cane Feed tables – Drag type

$$\text{Chain pull} = (C+W) (V+0.7H) + (L \times K)$$

Where C = Width table (ft) x height
Sides (ft) x 8.5
W=Weight of chain (lbs/ft)
V=Vertical rise of table (ft)
H=Horizontal centres of table (ft)
L=Length of table (ft)
K=Rubbing constant (chart 1)

To determine chain selection

$$\frac{\text{Chain pull}}{\text{No. of strands}} = \text{Chain pull / strand}$$

This value should not exceed 10% of the breaking load of chain chosen (this takes into consideration speed correction and service factors)

Auxiliary / Main Carrier Chain

$$\text{Chain pull} = (C+W) (V+0.4H) + (L \times K)$$

Where C = Value from chart 2
Against max. T.C.H
K= Rubbing constant (chart 1)
W=Weight of chains and slats (table 1)
V=Rise of carrier (ft)
H=Horizontal centre of head and tail shaft (ft)
L=Total length of carrier (ft)

To determine chain selection

$$\frac{\text{Chain pull}}{\text{No. of strands}} = \text{Chain pull / strand}$$

This value should not exceed 10% of the breaking load of chain chosen (this takes into consideration speed correction and service factors)

Chart 1

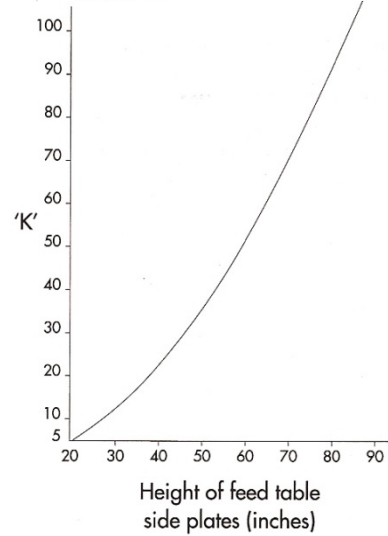
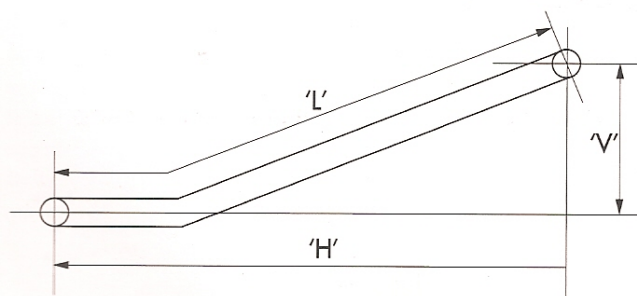
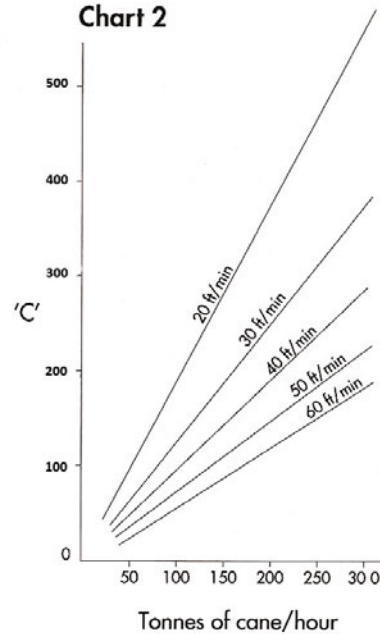

Chart 2



Carrier Width (Inches)	Average Values (LBS)		
	Regular Rollers		Outboard Rollers
	2 Strands	3 Strands	
Up to 60	101	126	200
Up to 66	106	131	213
Up to 72	111	136	226
Up to 78	116	141	239
Up to 84	121	146	252

Table 1



Guide Lines On Chain Selection For Sugar Mill Carriers

It has become apparent that with increasing throughput within the sugar mills, the carrier chains are tending to come into more frequent contact with sugar juices. These juices can promote corrosive attack on the articulating parts of the chain, resulting in rapid wear.

The increase in mechanical harvesting with its associated washing process also leads to corrosive conditions in which the carrier chains must operate. Whilst the standard cane carrier chains have ample wear resistance for traditional methods of sugar cane handling, modern harvesting methods have often necessitated the use of carrier chains having stainless steel articulating parts.

The grade of stainless steel selected is, of necessity, a compromise between wear resistance and corrosion resistance. The result being chains which give good service under wet and / or acid conditions, but if incorrectly used in totally dry conditions these chains with stainless steel components have inferior wear resistance to the standard chains.

In particular, the stainless versions of the carrier chains have proved successful in intermediate carriers where strength requirements dictate the use of steel chains. Details of the potential use of the carrier chains in the various sugar mill applications are given in the table. The sugar mill engineer's knowledge of the conditions applying in his own mill will enable him to make the appropriate choice.

Chain Number	Allowable Chain Pull		Breaking Load		Component	Material Code	Recommendations for use in carrier types			
	lb.	kgf	lb	kgf			Auxiliary Carrier	Main Carrier	Intermediate Carrier	Bagasse elevator & Carrier
Standard 09060	6,350	2,880	60,000	27,200	Pin Bush Roller	CTI CC CC				
Stainless 09060	6,350	2,880	60,000	27,200	Pin Bush Roller	ST ST ST				
SS996	6,350	2,880	70,000	31,750	Pin Bush Roller	AT CC CC				Not Applicable
Standard 09061	6,350	2,880	85,000	38,600	Pin Bush Roller	AT CC CC				
Stainless 09061	6,350	2,880	85,000	38,600	Pin Bush Roller	ST ST ST				
DN2184	7,100	3,224	80,000	36,300	Pin Bush Roller	AC CC CC	Not Applicable	Not Applicable	Stainless 	
Standard 1796	7,500	3,405	100,000	45,400	Pin Bush Roller	AT CC CC				
Stainless 1796	7,500	3,405	100,000	45,400	Pin Bush Roller	ST ST ST				
Standard SS600	7,500	3,405	100,000	45,400	Pin Bush Roller	AT CC CC				Not Applicable
Stainless SS600	7,500	3,405	100,000	45,400	Pin Bush Roller	ST ST ST				Not Applicable
Standard 09063	8,300	3,768	140,000	63,500	Pin Bush Roller	AT CC CC				Not Applicable
Stainless 09063	8,300	3,768	140,000	63,500	Pin Bush Roller	ST ST ST				Not Applicable
C.O.B.R.A. CARRIER OUTBOARD ROLLER ASSEMBLY having 6" (152mm) dia. On tread renewable Outboard Rollers and sleeves in heat treated white iron										
C2614	19,000	8,626	140,000	63,500	Pin Bush Roller	AT CC CC			Not Applicable	Not Applicable

Recommended

Not Recommended

Only used in wet or corrosive conditions

Material Code – Components

- CC Carbon steel case hardened
- CTI Carbon steel heat treated & induction hardened
- CT Carbon steel heat treated
- AC Alloy steel case hardened
- AT Alloy steel heat treated
- ST Stainless steel heat treated

Specifications of chains described in this brochure are subject to change.

* The tabular dimensions and weights are approximate and are not binding. Design improvements may result in variation from the published figures and verification is recommended.

Ewart Chain

EWART CHAIN LTD

Colombo Street
Derby
DE23 8LX
England
UK

CALL: +44 (0)1332 345451
EMAIL: sales@ewartchain.co.uk
WEB: www.ewartchain.co.uk